

BECKHOFF New Automation Technology

Benefit from intelligent
drive technology.
XTS. The eXtended Transport System.



IPC

I/O

Motion

Automation

XTS optimises production and sales: by essentially optimising the drive concept.

Rotatory drive



Linear technology



Companies around the globe today are facing profound changes with the challenges of getting ready for Industry 4.0. Markets are developing new dynamics, customer needs are becoming fragmented and product life cycles are getting shorter. How can industrial production be responsive and sustainable at the same time? How can production managers today ensure they are creating products of the desired quality, sometimes with rapidly changing character-

istics and in different lot sizes – while being forced to reduce unit costs all the time? As a specialist in PC-based control technology, Beckhoff offers you an innovative solution that resolves the apparent contradiction: the eXtended Transport System XTS – a drive technology that combines all of the advantages of linear and rotary drive concepts. An Industrial PC (IPC), any number of magnetically driven movers, guide rails and motor modules that can be combined

at will already provide for an almost arbitrary and highly flexible configuration. The movers can synchronise their motion as well as combine to form groups and accumulate; they can create clamping forces in motion, recover energy through regenerative braking and use return paths for transport purposes, too. This cable-free PC-controlled transport system ensures a leading edge on two levels. On the one hand, production managers can use XTS to dramatically reduce





their production costs. While on the other hand, as soon as a product has left the factory, XTS helps to optimise distribution costs – both during transport and at the point of sale.

The eXtended Transport System XTS:

- Just a small number of components: an Industrial PC, cable-free movers, guide rails and motor modules
- A range of different geometries, lengths, radii and applications
- For significant cost reductions in production and sales

XTS reduces the footprint by 30 %: by dramatically reducing machine sizes.

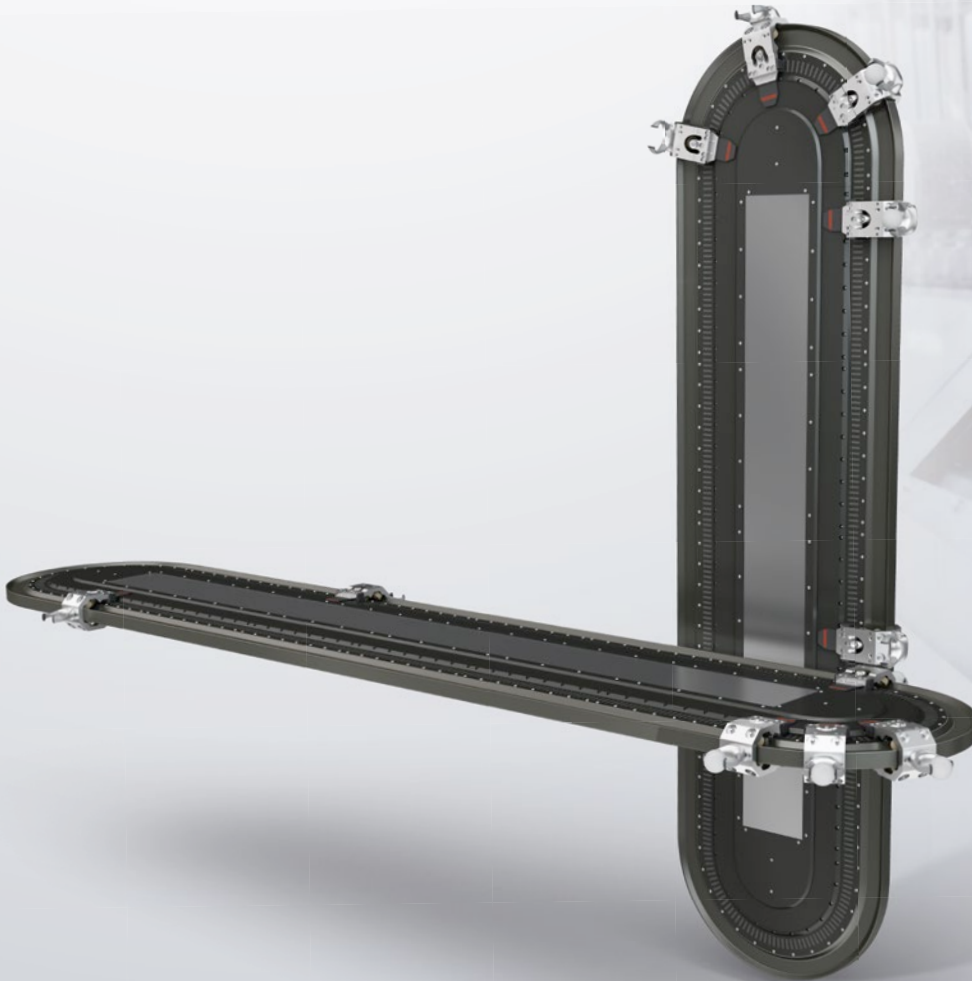

The XTS linear transport system offers an extraordinarily space-saving geometry owing to its straight and curve modules. Thanks to XTS, the “usual” footprint of a machine can be reduced by at least 30 percent without fail and usually even by more than 50 percent. This immediately delivers massive cost savings since maintenance of one square meter in production facilities costs approx. 5,000 euros per annum in terms

of cleaning, air conditioning and pro rata room or building costs. At the same time, XTS allows the overall height of a machine to be reduced by more than 50 percent since vertical processes can be converted to horizontal processes. The result: maintenance buildings and production halls can be built lower. At the same time, XTS protects your investment in machinery. That is because PC-based control technology allows sim-

ple, software-based format changes. Machines can be ordered according to current requirements and later easily be adapted to new requirements by simply changing software parameters – in a matter of seconds, without interrupting the product flow and without mechanical adjustment. This is especially beneficial in packaging because of the permanent modifications and quality improvements that have to be implemented in that

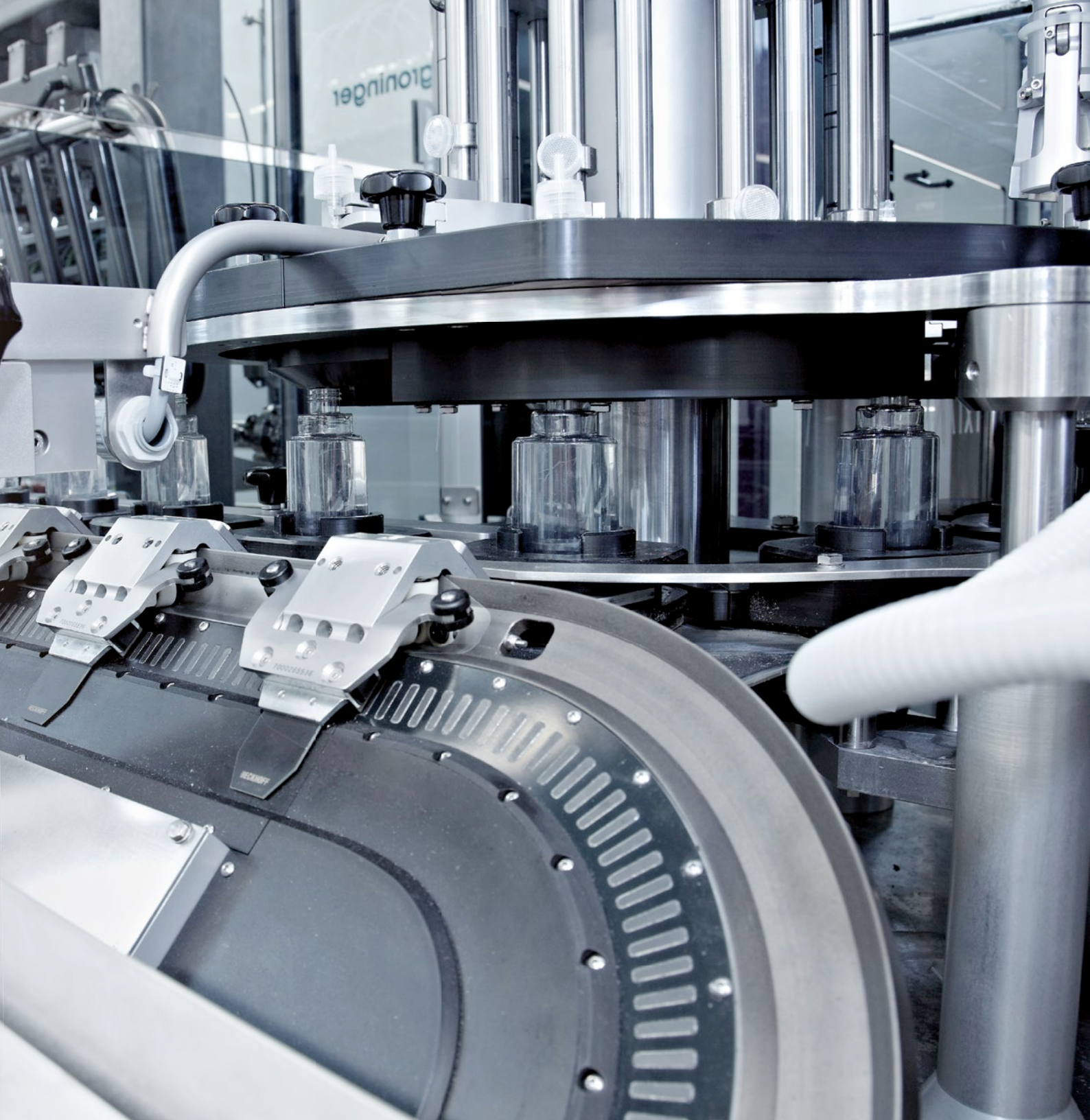

industry. Companies can drive products on their systems even for just a few hours, achieve extremely short product life cycles and extend the average useful life of their machines by between three and nine years.

XTS is adaptable:

- Freely selectable track layout and number of movers
- Individual controllability
- Ease of integration into existing environments
- Optimising production efficiency and useful life

XTS eliminates downtimes: by changing lot sizes via software functionality.

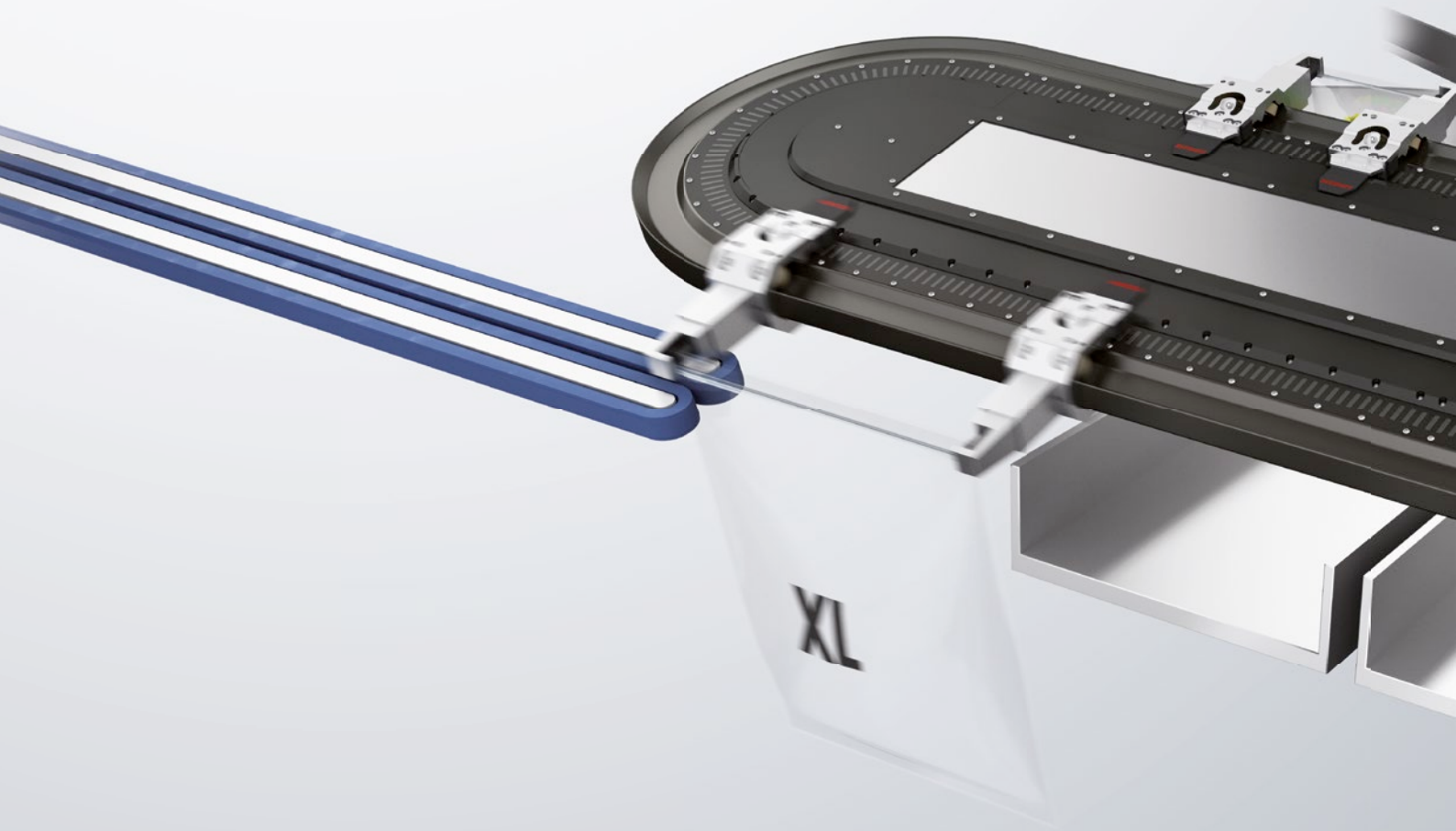

Anyone responsible for ensuring smooth production processes has a major interest in eliminating the worst enemy of profitability: downtimes. These are often required when implementing format changes – and are still a regular occurrence in sectors such as the packaging industry. It is hard to avoid downtime, for example, if the lot size changes from 4 to 10, as the machine generally has to be converted mechanically –

with all of the economic drawbacks this involves. The software-based XTS concept bypasses these downtimes. Since the control software can be simply reparameterised to suit a new lot size, the production of the new lot size can start immediately and also be changed again later on. XTS consequently enables lot sizes of 1 just as easily as mass production. Your machine can continue producing without interruption in both cases.

The practically unlimited freedom in terms of programming each individual mover therefore allows maximum individualisation of production using the simplest of methods – and at the same time optimum utilisation. Companies who use XTS for production can thus respond significantly faster and more efficiently to market demands than their competitors. All in all, this equates to a significant competitive edge in an Industry 4.0 context.

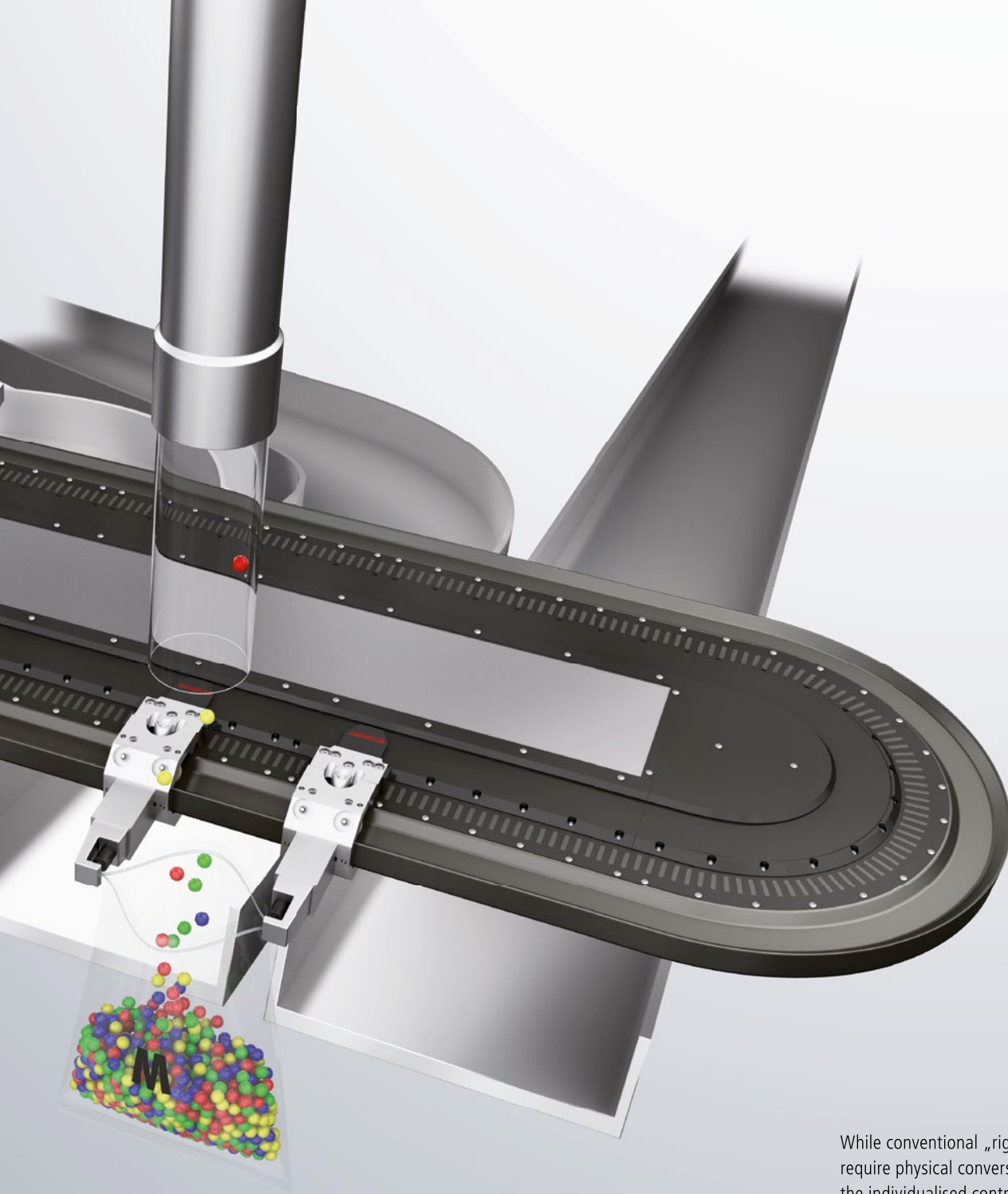

While conventional „rigid“ transport systems require physical conversion to change lot sizes, the individualised control of every single XTS mover enables immediate conversion to lot sizes of 1 in a matter of seconds.

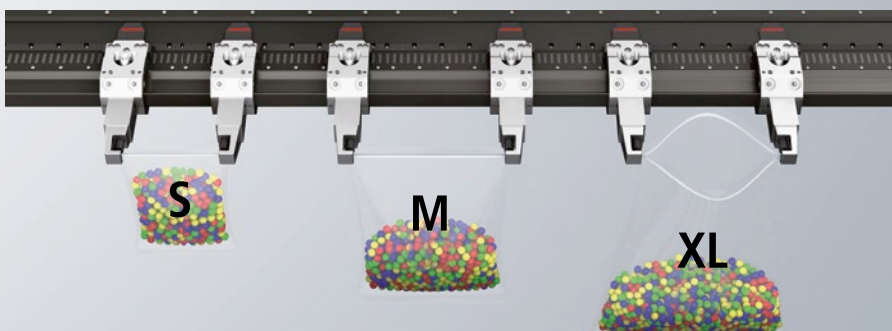

- XTS allows extremely short product life cycles, even in a matter of hours.
- Conversion within seconds
- No downtimes owing to conversions

XTS increases output and efficiency: by enabling continuous product flow.

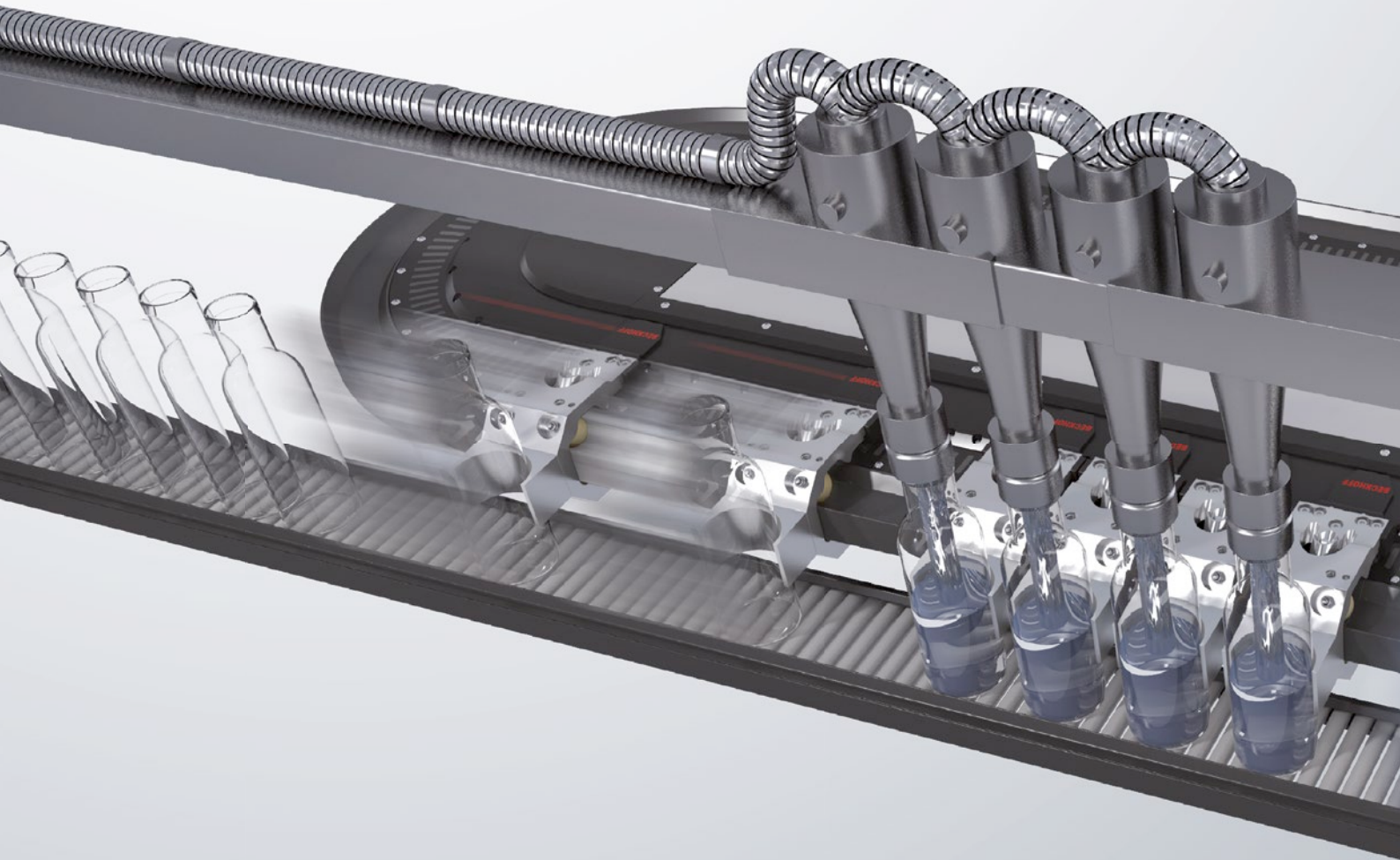

With outstanding dynamics, XTS allows selective processing without interrupting a continuous product flow: individual movers accelerate directly before and after the processing point and thus seamlessly re-join the product flow.

XTS optimises the precision of your production: PC-based control allows absolutely precise motion of the movers by means of magnetic fields. The highly dynamical control is enabled by the large bandwidth and real-time capabilities of EtherCAT. The result: the movers achieve enormous peak forces combined with extremely high acceleration values. Force limitation and jerk reduction are ensured in the same way as a sensitive response

and maximum positioning accuracy. This unique combination of precision, dynamic and speed delivers enormous advantages and an excellent flexibility in use. The flexibility is also demonstrated, for example, by the option of individual product transport, allowing the production process to be accelerated, stopped and slowed down at any point on the path. XTS therefore allows a continuous product flow, which can optionally be processed

discontinuously at certain points. The result: all upstream and downstream machines can operate more uniformly. This in turn reduces wear and tear, energy consumption and noise emission. And the ecological footprint can not only be enhanced through reduced machine sizes but also by energy savings in the ongoing production process, because XTS enables energy recovery during braking of up to 60 percent.

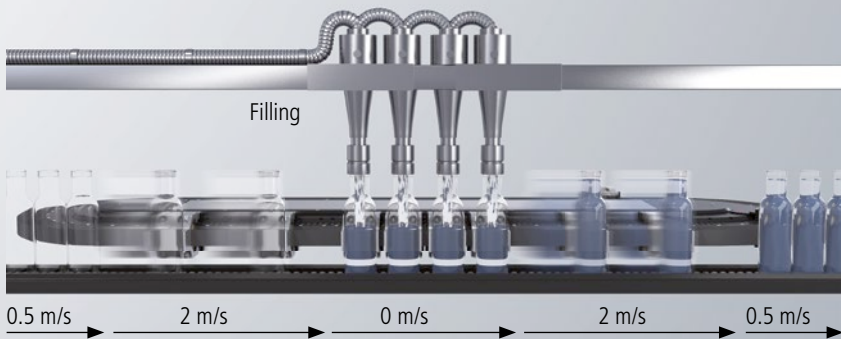
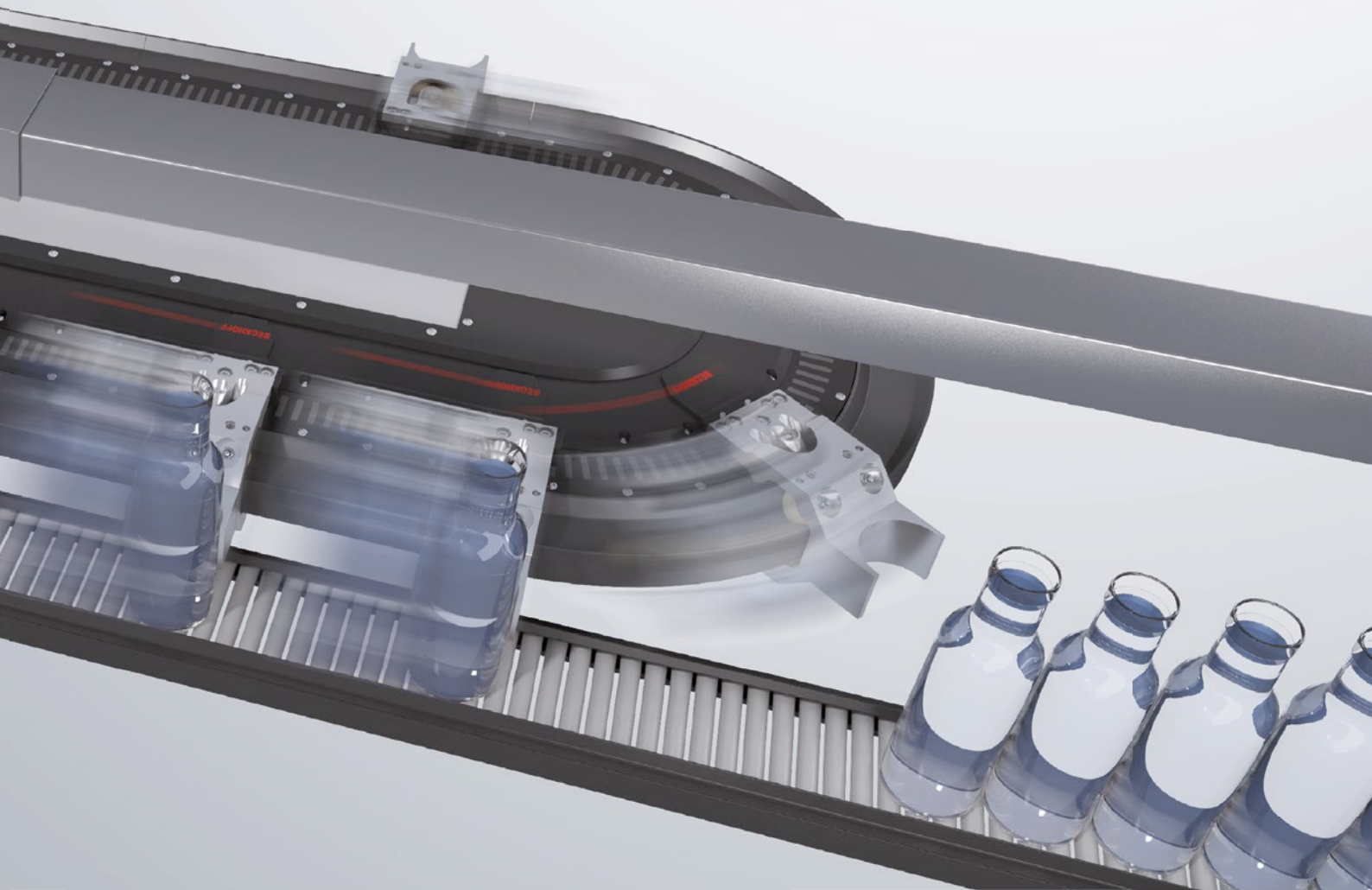

- Jerk-free acceleration of more than 100 m/s^2
- Maximum positioning accuracy
- Synchronisation, selective stopping and starting at any position
- The product flow is maintained in any case.

XTS reduces packaging volumes by 25 %: by allowing extremely precise positioning.

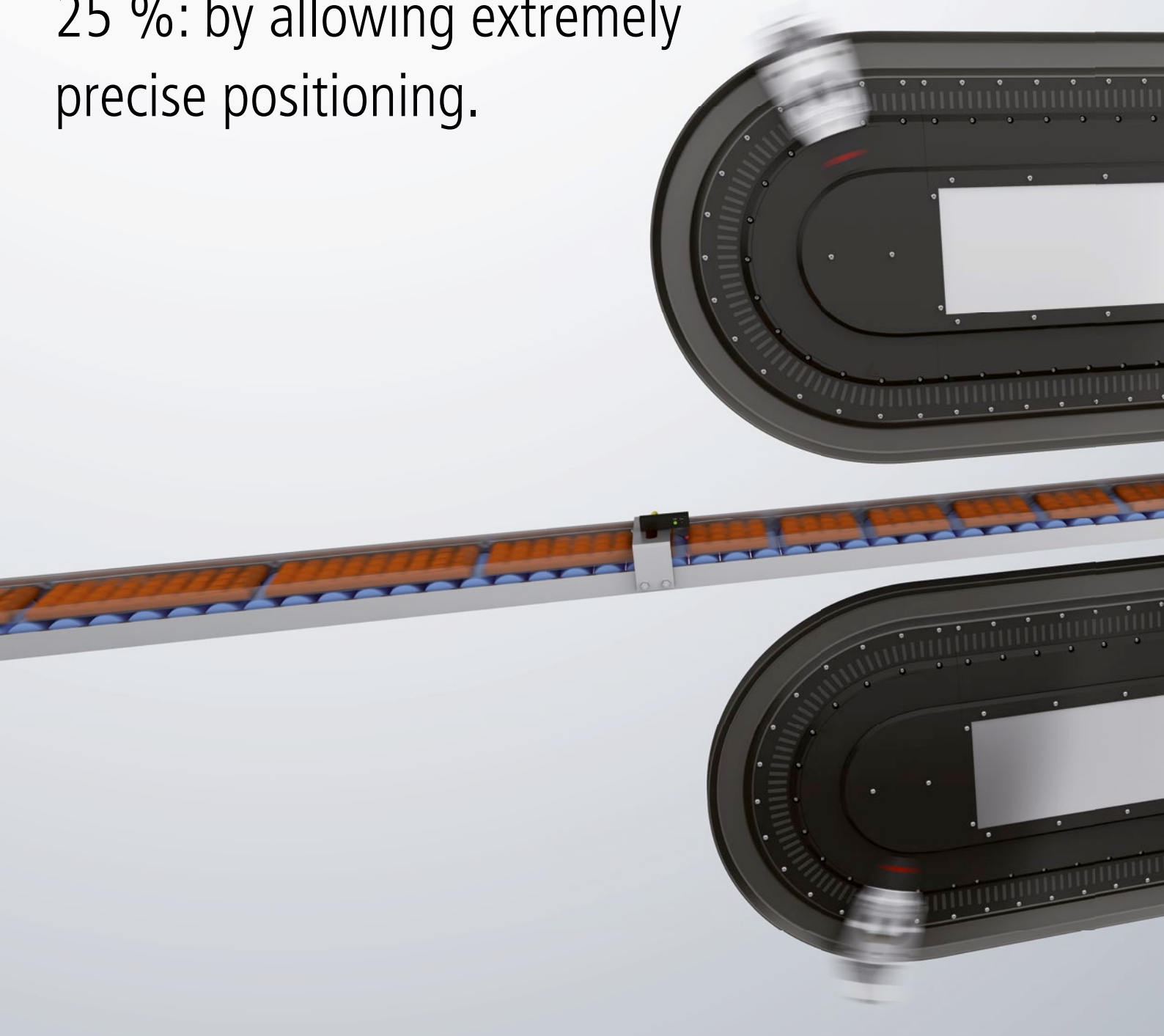

Especially for packaging applications, XTS not only offers numerous advantages in production engineering, but also compelling economic benefits, which only become apparent after completion of the production process. With XTS, packaging solutions can be implemented that exactly adhere to the required filling quantities while also reducing the amount of packaging material. Secondary packaging can be packed more closely to products, thus reducing the overall

packaging volume. This is possible through the outstanding positioning accuracy of the individual movers. As a result, the challenge of ensuring that the sealing seam is placed as close to the product as possible can be mastered efficiently: EtherCAT-based control allows fast and precise synchronisation of printing marks and sealing guillotine. When the products packaged in this way are then forwarded to be shipped, the technology immediately begins to pay off, because transport volu-

mes are reduced and the company saves on transport costs. Significant economic advantages can also be achieved at the point of sale, with the packing density being increased significantly and expensive shelf space being utilised more effectively. For example, Beckhoff was able to reduce transport volumes for a customer in the food industry by 25 percent with XTS, increasing the packing density on the shelf by an impressive 60 percent at the same time.

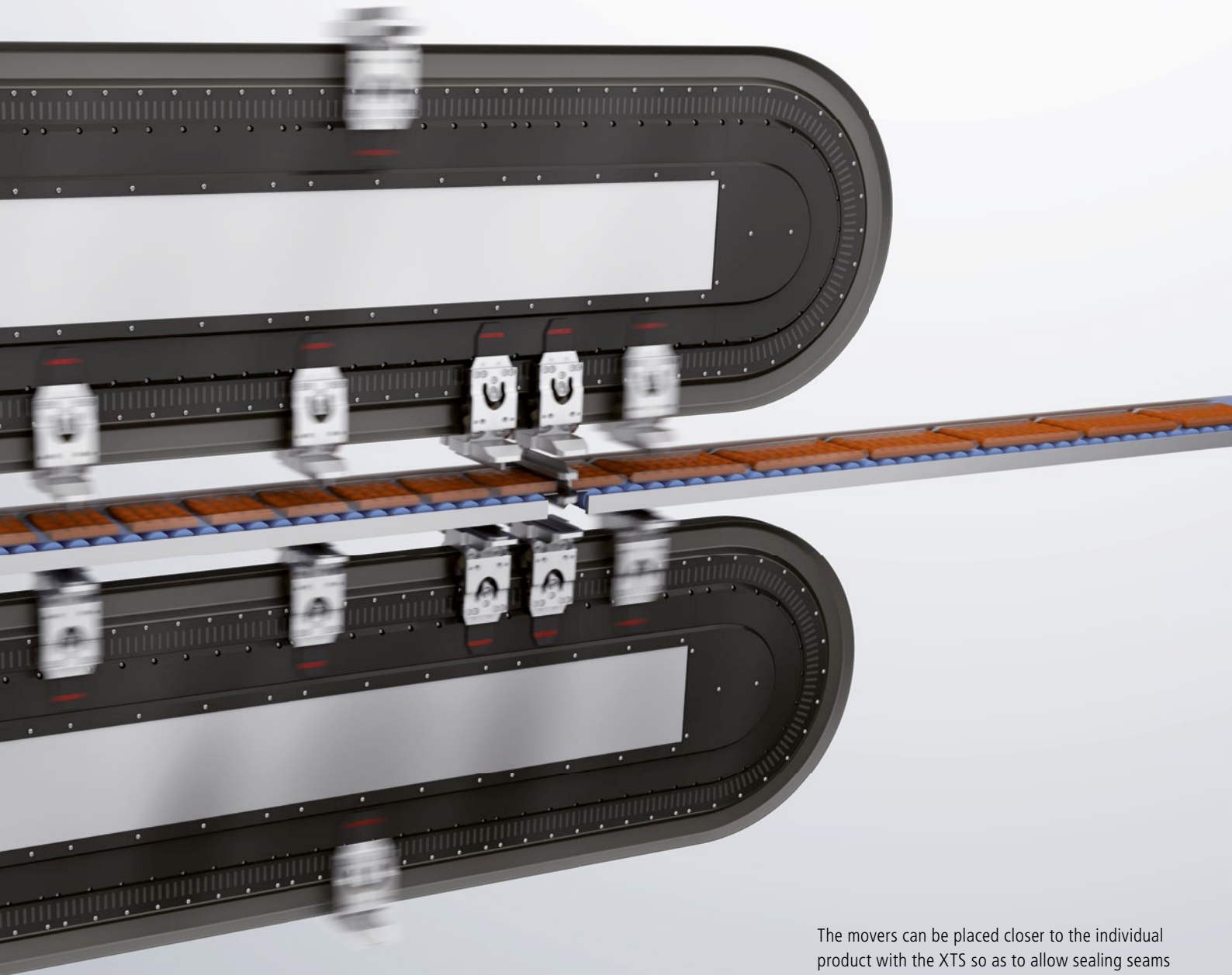

The movers can be placed closer to the individual product with the XTS so as to allow sealing seams to be positioned as closely as technically feasible. This pays off for the user in three ways: reduced packaging material, lower transport volumes and higher shelf densities.

Placing of a sealing seam:

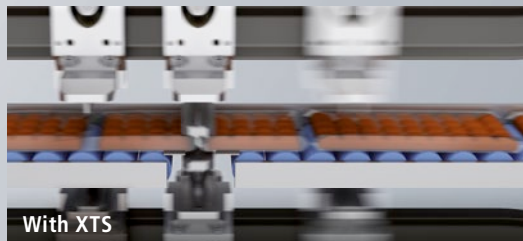
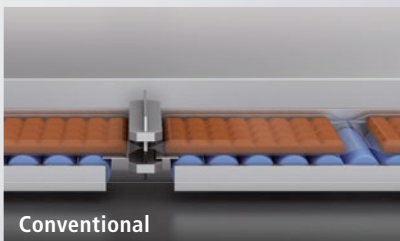

- Reduced packaging volume
- Reduced transport volume
- Reduced transport costs
- Increased shelf density

XTS reduces time-to-market by several weeks: by radically simplifying software and hardware engineering.

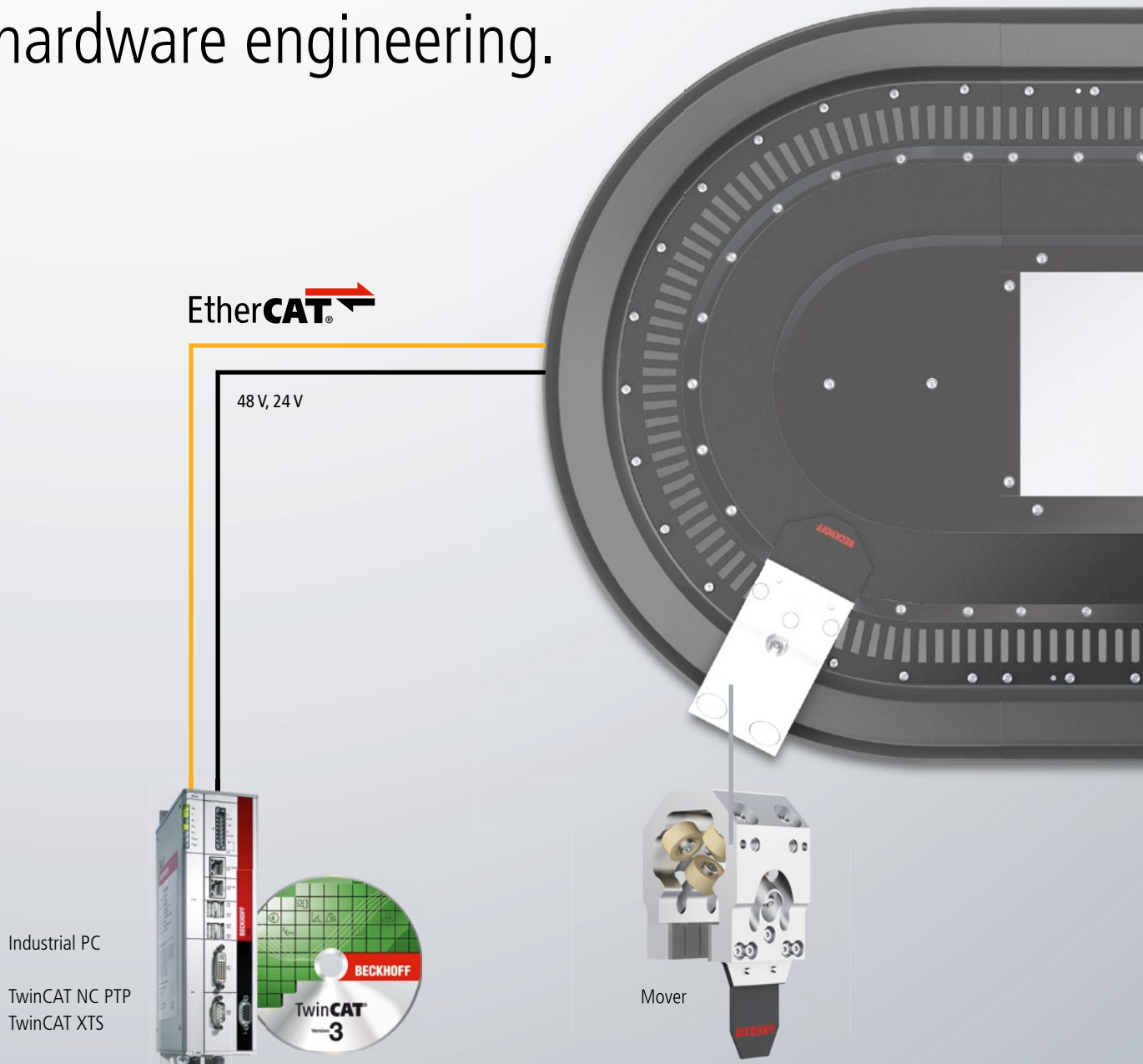

XTS maximises efficiency both in terms of implementation and engineering. The number of mechanically moving parts is dramatically reduced; only modules and movers have to be kept in stock for subsequent modifications. In short, XTS allows all mechanical components to be standardised, while individualisation is carried out via software modifications. The engineering can be completed in at most 30 days, thus reducing the time-to-

market by several weeks. Thus companies can gain a competitive edge because they can respond faster to changing market needs. New customer requirements are incorporated in the XTS development and transferred to existing machines by simply updating the software. In addition to radically simplifying engineering, XTS provides another key benefit by reducing the number of hardware components.

Only three components are needed apart from the TwinCAT control software and the fast Ethernet fieldbus EtherCAT: motor modules, guide rails and movers. The motor modules, available as straight and curved track sections, contain all required active functionalities including displacement measurement. The mover contains magnetic plates which, together with the coils in the motor module, generate propulsive forces. Movers and

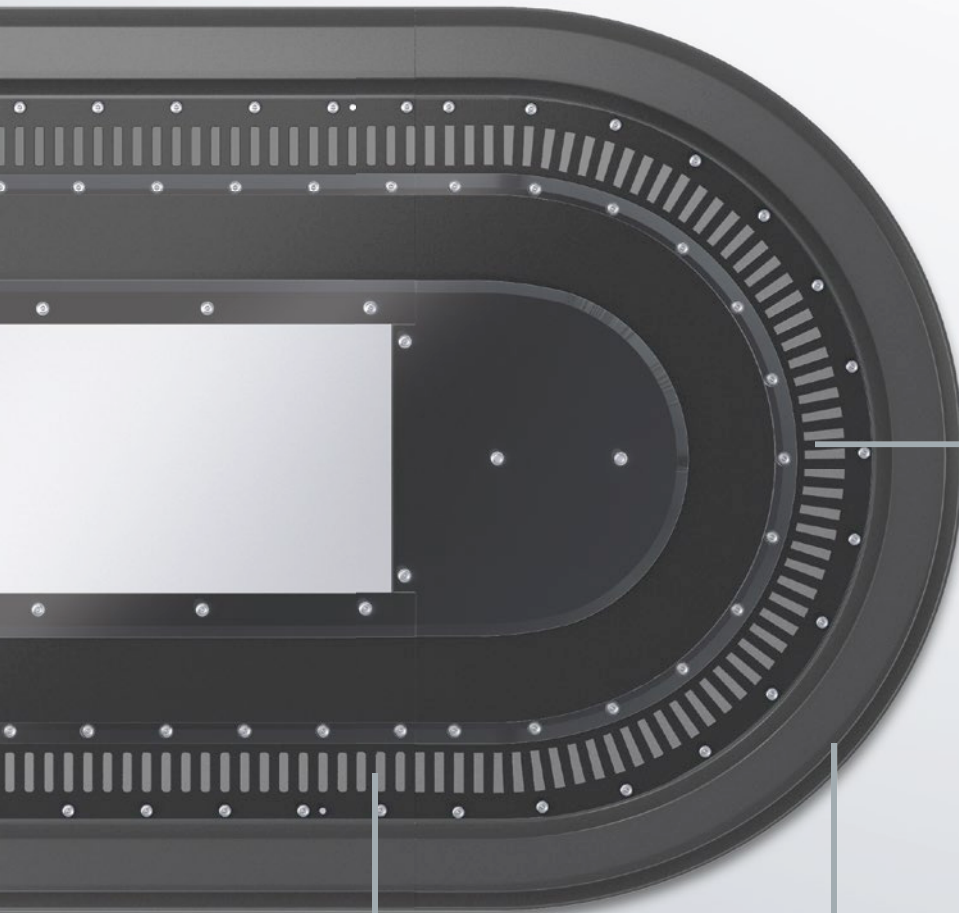

The XTS components:

- Curve sections
 - 2 or more straight sections
 - 1 or more movers
 - Beckhoff IPC
 - TwinCAT NC PTP
 - TwinCAT XTS extension
 - Power supply units
- ➔ Almost no control cabinet and no wiring necessary

Straight motor module

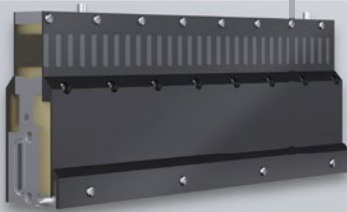

Guide rail



Curve motor module



guide rail are perfectly matched to each other allowing good running characteristics and low wear.

- Motor modules in straight and curved sections can be combined as required.
- Wear-free movers
- Movers allow product spacings of only 62 mm.
- Optimised geometry allows driving through curves with full dynamics and negligible heat dissipation.

System components

To create a track the single parts with protection class IP 65 are mounted at the machine frame.

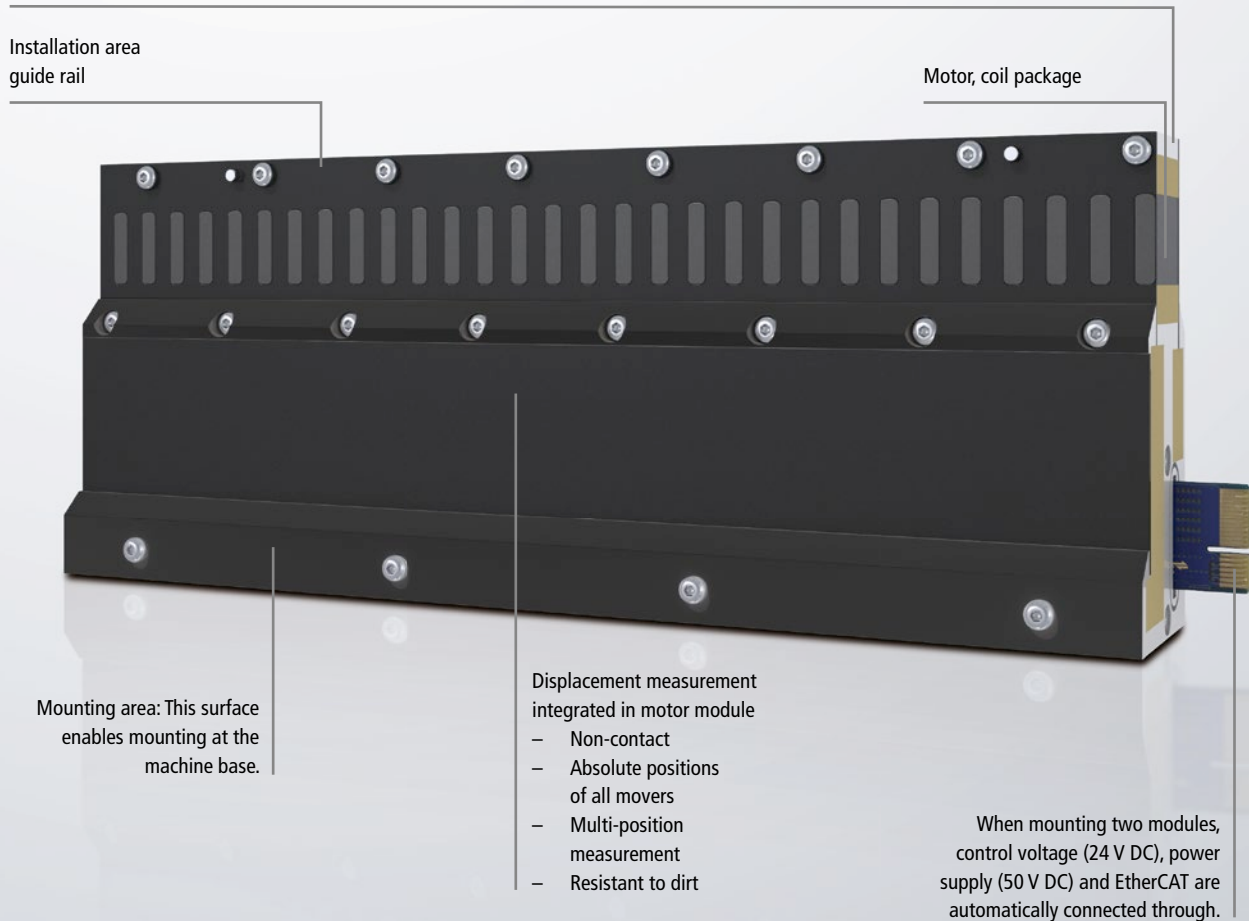

Guide rail system

Movers and guide rails are optimally matched to each other. The geometry of the rail and the hard anodised aluminium of the surface in combination with the running surface of the mover rollers allow good running characteristics and low wear. Lubrication of the system is not necessary.

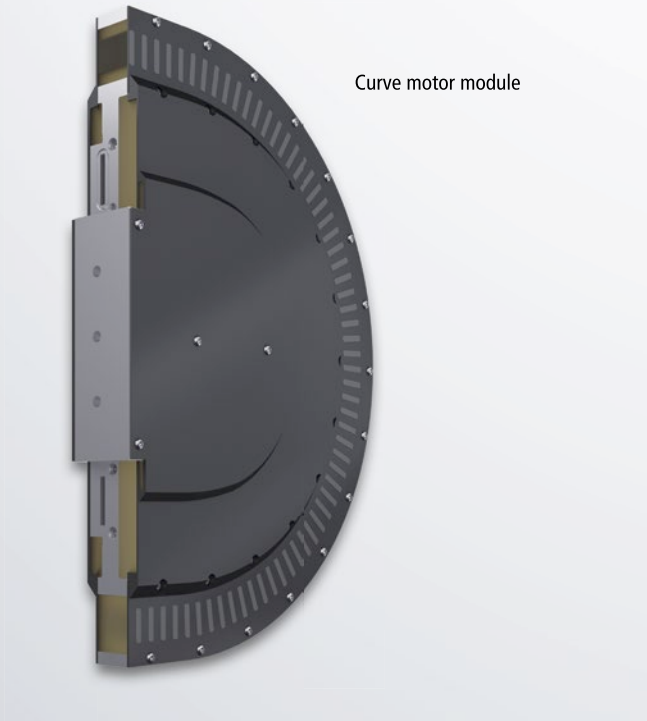

Curve motor module

Motor module

The motor module contains the electromagnetic coils and all other active functions necessary for the operation of the system. Only a power supply and an EtherCAT connection are required. The motor module contains no moving parts and is not subject to any wear.

- Fully integrated linear motor with power electronics and displacement measurement
- Coil arrangement and mechanical structure make up a ready-to-use unit.

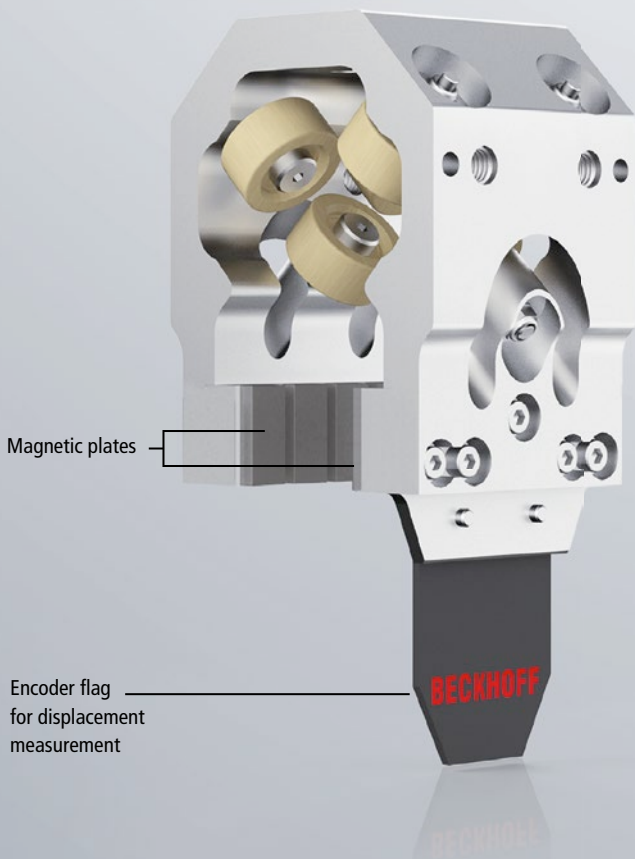

Mover

The mover contains magnetic plates which, together with the coils in the motor modules, can generate propulsive forces. It absorbs the attractive forces of the magnets on both sides and compensates them as far as possible. This allows the rollers of the mover to run at high speed in the guide rail with low wear. The rollers are equipped with a particularly wear-resistant synthetic running surface. The tensioning of the rollers prevents backlash and is at the same time designed for low wear. Consequently, the lifetime of the rollers depends on the payload. A mechanically robust encoder flag conveys the mover position to the motor module.

Basic functions

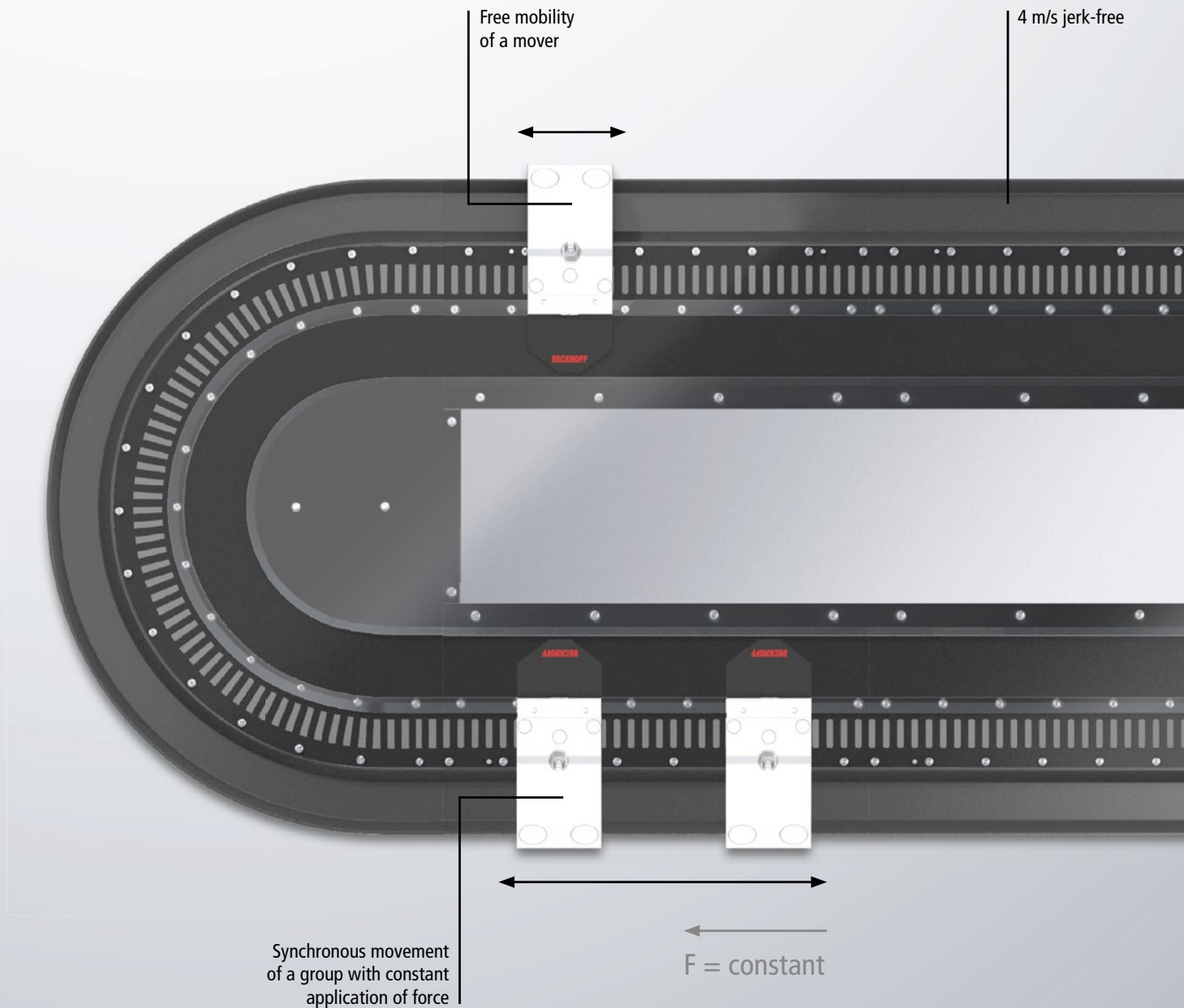

Free mobility of a mover

A mover can be moved freely over the entire path. It can brake, accelerate, position or exert a constant force at a standstill or also when in motion. Like every linear motor, the mover can synchronise itself to other movements, but without cables on the moving carriage, thus offering the maximum possible flexibility. When arranged in a circle the movers can drive endlessly and follow the product flow.

Free mobility of several movers

The movers can all be moved independently of one another. They can be positioned at absolute positions along the entire travel distance. In addition, they can be moved relatively to each other and always avoid a collision with their neighbour. They can automatically accumulate themselves, thus representing a moved buffer from which a moved destination can be driven to with very high dynamics.

Synchronous movement of a group

In the running movement groups can be formed that stop together or drive past processing stations with a specified speed profile. This formation is supported any desired number of times on the path. The size of the group (number and spacing) can be changed dynamically.

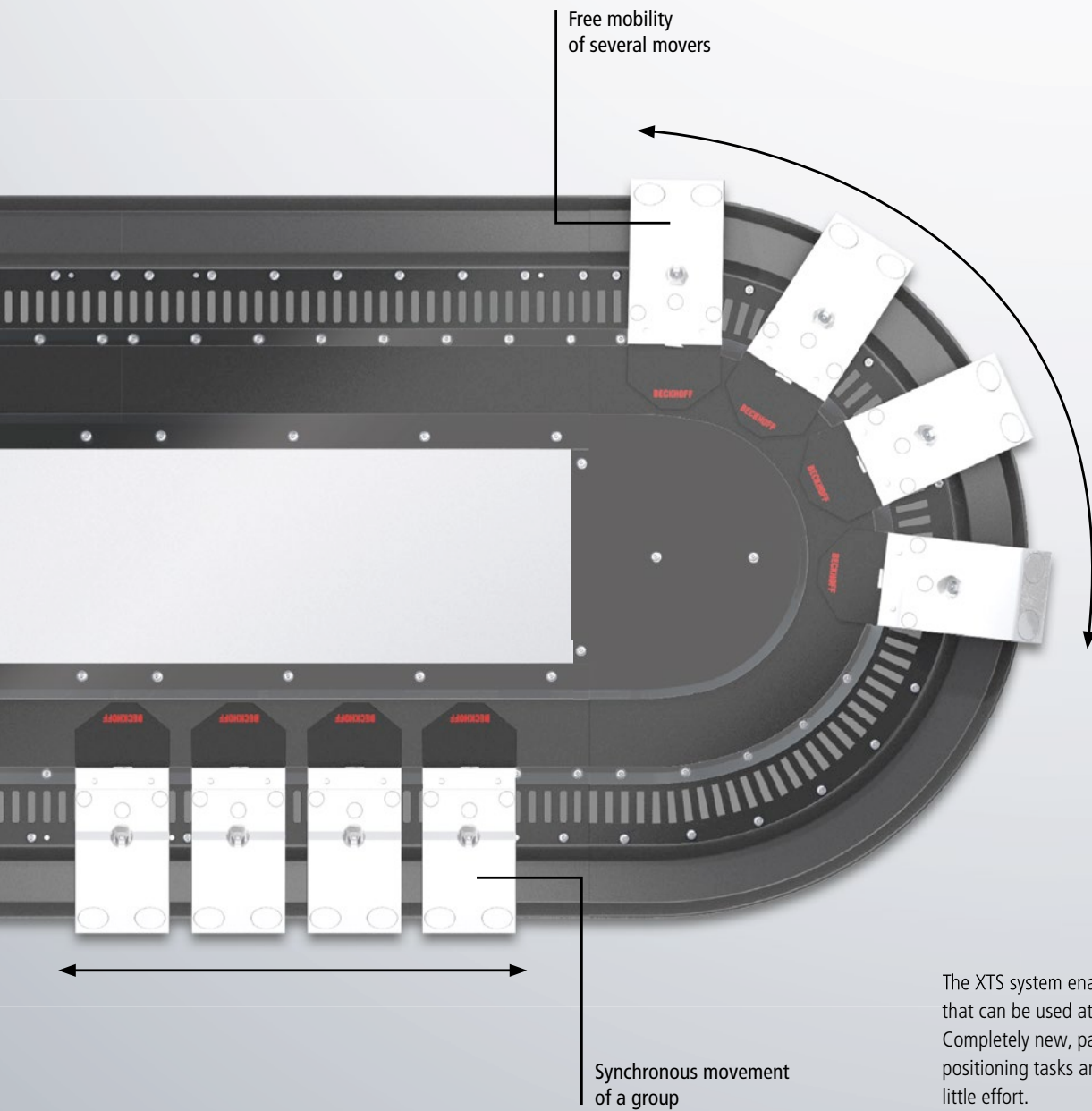

The XTS system enables a new class of functions that can be used at the same time in several places. Completely new, particularly flexible: transport and positioning tasks are economically solvable with little effort.

Constant force

A mover follows another with a defined force. It can apply a "clamping force" while at the same time following a movement, for example in order to hold a product. For other applications the force can be limited so as not to place an unnecessary load on a product under any conditions. The acceleration and centrifugal forces can additionally be limited, for example for the transport of liquids in open containers.

Unrestricted curve function

The total travel distance becomes the utilisable path. Outward and return path and also the curves are available for material transport and processing. This results in very compact application solutions that make completely new machine concepts possible.

- Full mobility (forward, backward, continuous travel of the movers)
- Independence: Each mover can be moved autonomously.
- Collision avoidance: The collision of movers is automatically prevented.
- Arbitrary parameterisation: The control characteristics of each mover can be adapted at all times.

Configurations

Arbitrary number of movers



There are no system limits for the number of movers; consequently the number can be optimally adapted to the application. In practice the number is limited only by the available computing power of the PC.

Arbitrary system length

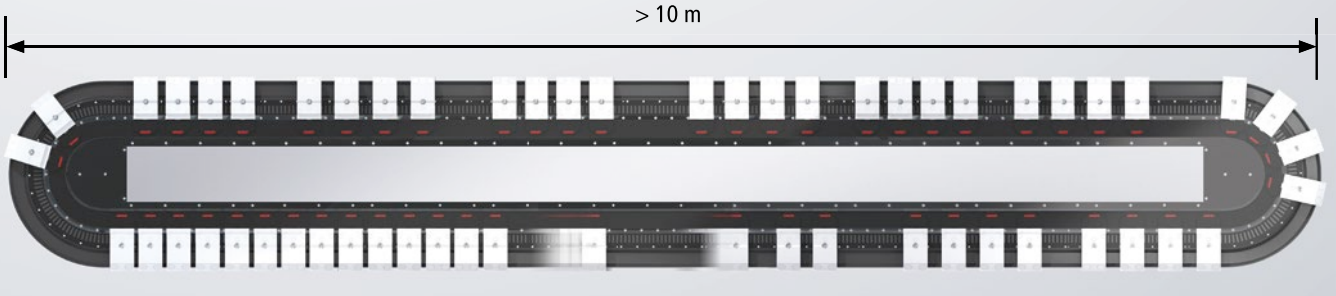

There are no length restrictions for the entire path. 10 m and more are technically possible.

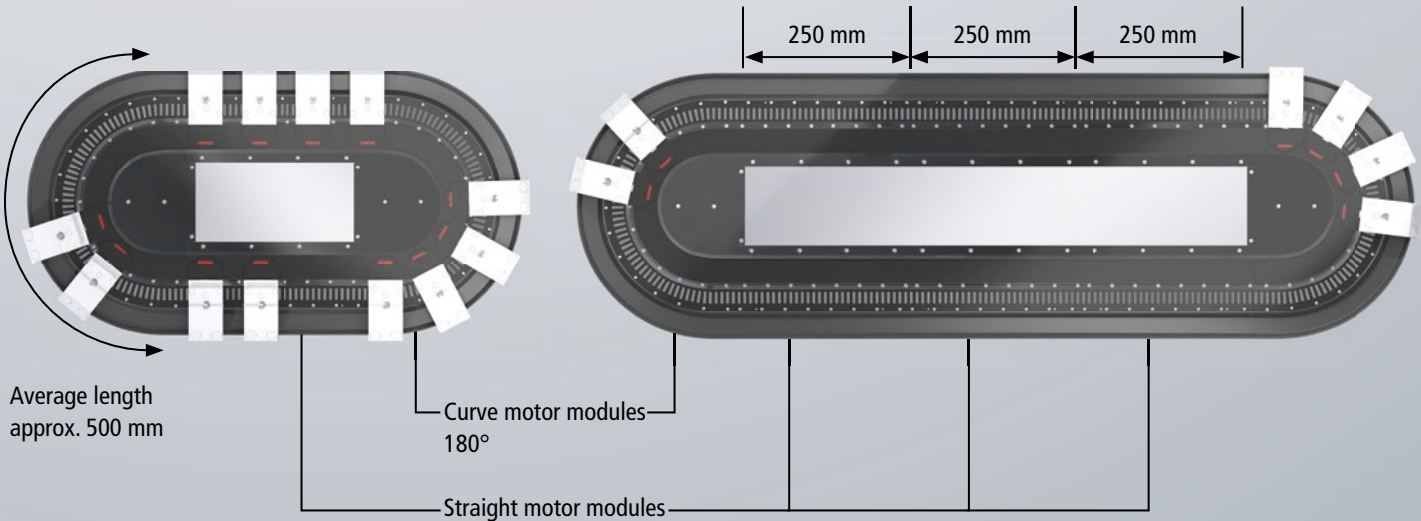

Trajectories



S-shape



Straight, not closed



Square



Rectangle



Circle, positive curve



Circle, negative curve

All motor modules can be combined as desired.

Areas of application

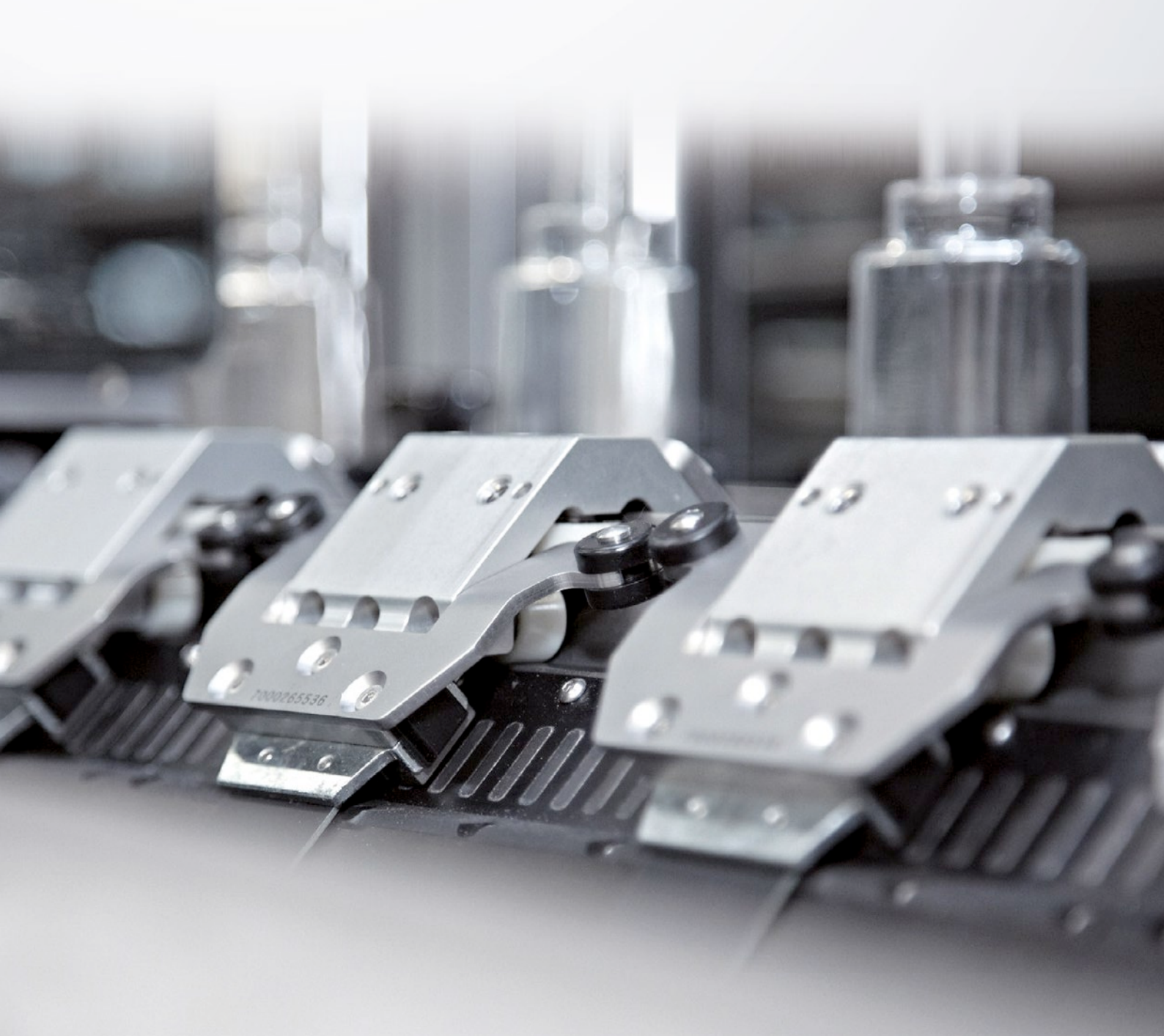

Flow of material in packaging and assembly technology:

High-speed material transport:

- Controlled movement at all times and all places on the transport path. No jerks and no unnecessarily large forces; high positioning accuracy at up to 4 m/s. Even open liquids can be transported.
- Dynamic buffer. The transported material can be accumulated and grouped during the movement.
- Synchronisation, stopping and starting can be accomplished at any of the stations on the entire path.
- Maximum use of the machine volume. Outward and return path as well as the curves can actively transport material.
- The movers of the XTS system can always run with the product flow. No return trip or return stroke is necessary.
- A format change during product changeover can be accomplished without stopping production – at „the touch of a button“ per software parameterisation.

Push product, adapt product spacing, reduce or increase product speed

Clamp and move product

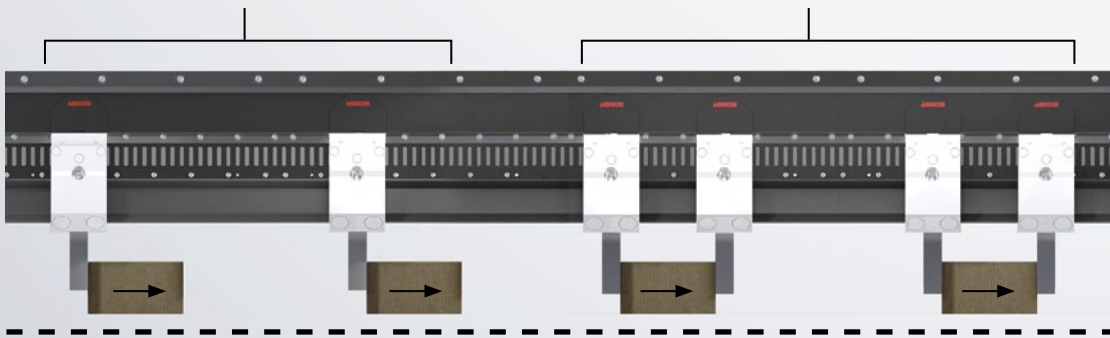

Transporting and discharging a product:

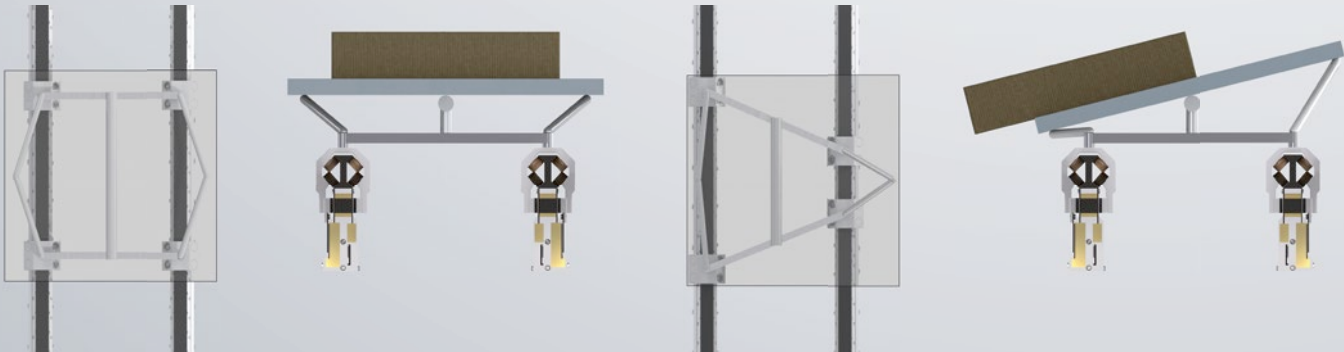

A package or a case is transported on a surface. The package is to be deposited at a station. The surface is tilted to the side and the package slides off. Four movers on two paths move the tilting surface with

the transported material. A change in the spacing of the movers with respect to each other generates a mechanical action that tilts the surface. The transported material can be prevented from sliding off

when driving through curves by an inclined position and can be specifically deposited at another place while driving or after stopping.

- Low mechanical wear since only the mover requires mechanical bearings. There is no need for: gears, belts, guide rollers and clamps.
- Reduced energy consumption due to lower friction and possible regenerative braking (the brake energy from one transported material can accelerate another).
- High positioning accuracy reduces the expenditure. The compensation of inaccuracies as required in common transport solutions is not necessary: stretching of chains due to load and wear, re-tensioning of toothed belts, mechanical backlash during a load change.

Areas of application

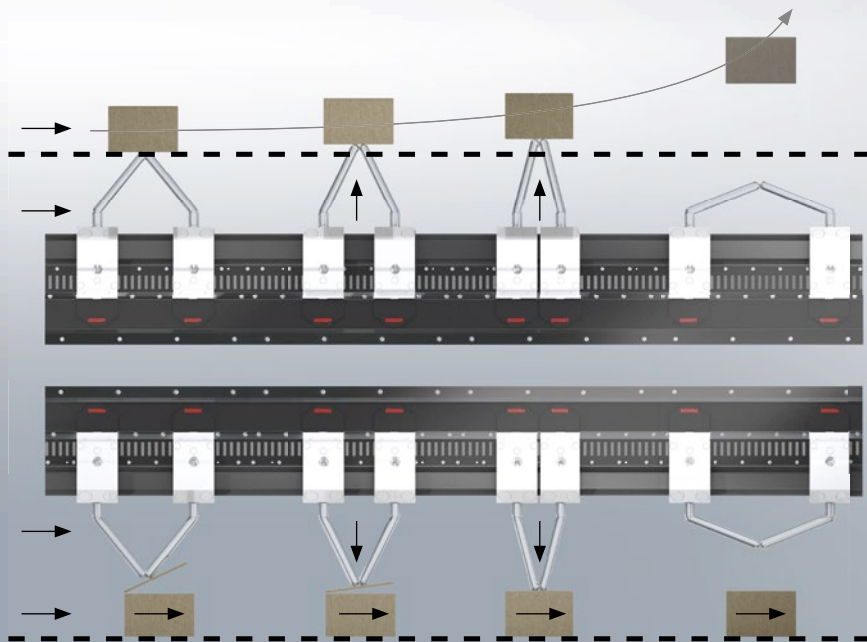

Kinematics in the linear motion in order to manipulate a product: lifting, pressing ...

A mechanical action generated by the relative movement between two movers creates an additional movement that can manipulate a product. Transported materials can be pushed upwards or to the side. A product can be closed or processed in some other way while moving.

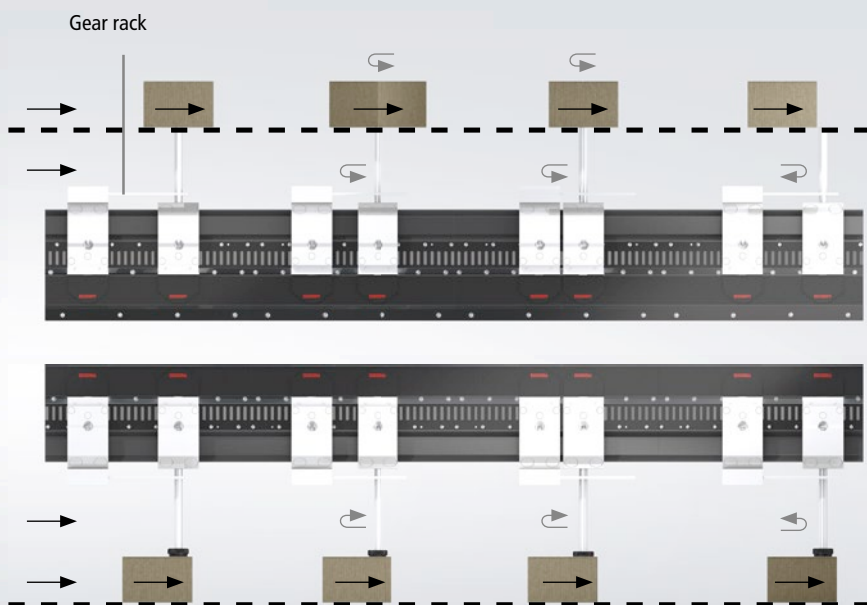

Kinematics in the linear motion in order to manipulate a product: turning, closing cap ...

A rotary movement can be generated between two movers by a suitable mechanical action. That way, a cap can be screwed on or the product can be twisted, for example.

Distribution system

Functioning as a distribution system, the XTS splits an incoming product stream into multiple streams (two in this case) inexpensively and with great flexibility.

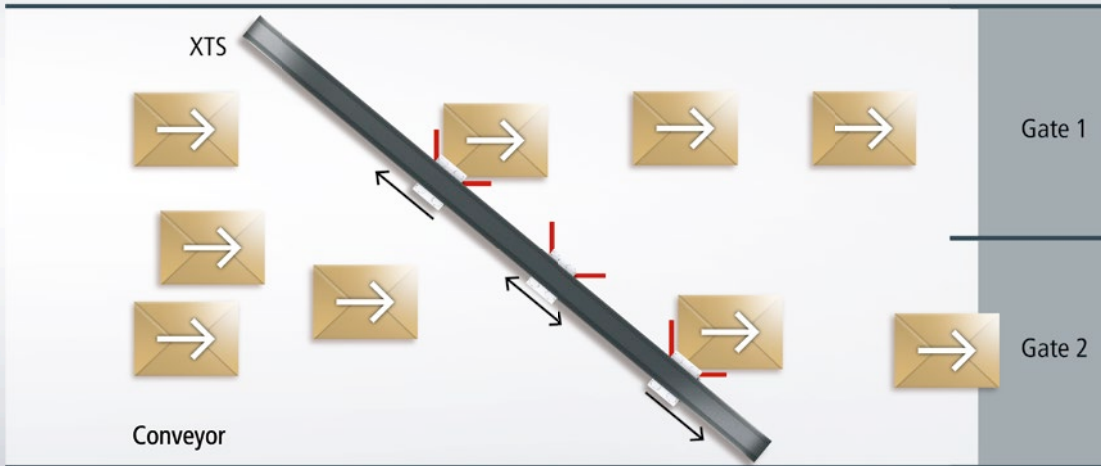

Feeder with distance adjustment

The XTS makes it easy to implement a feeder with distance adjustment that synchronises product arriving at different intervals with the downstream process.

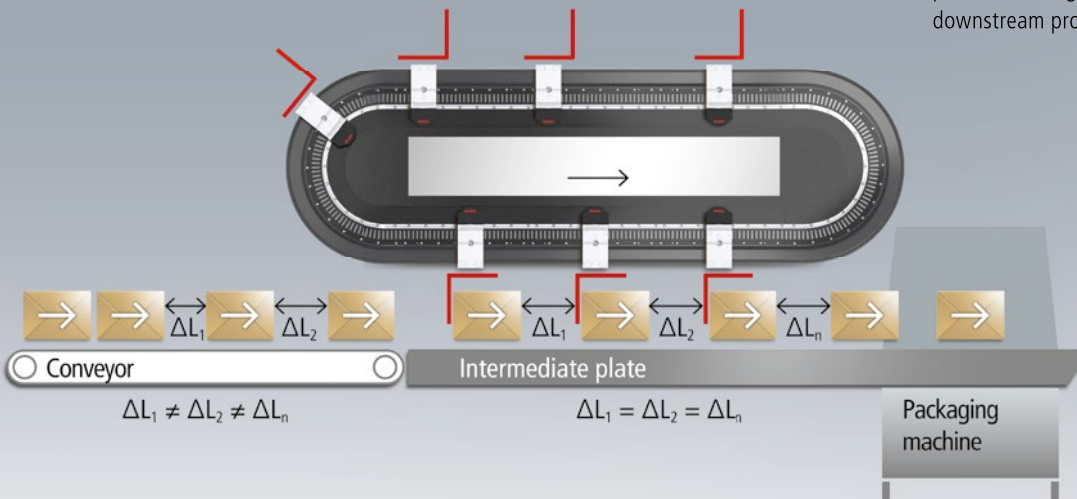

Areas of application

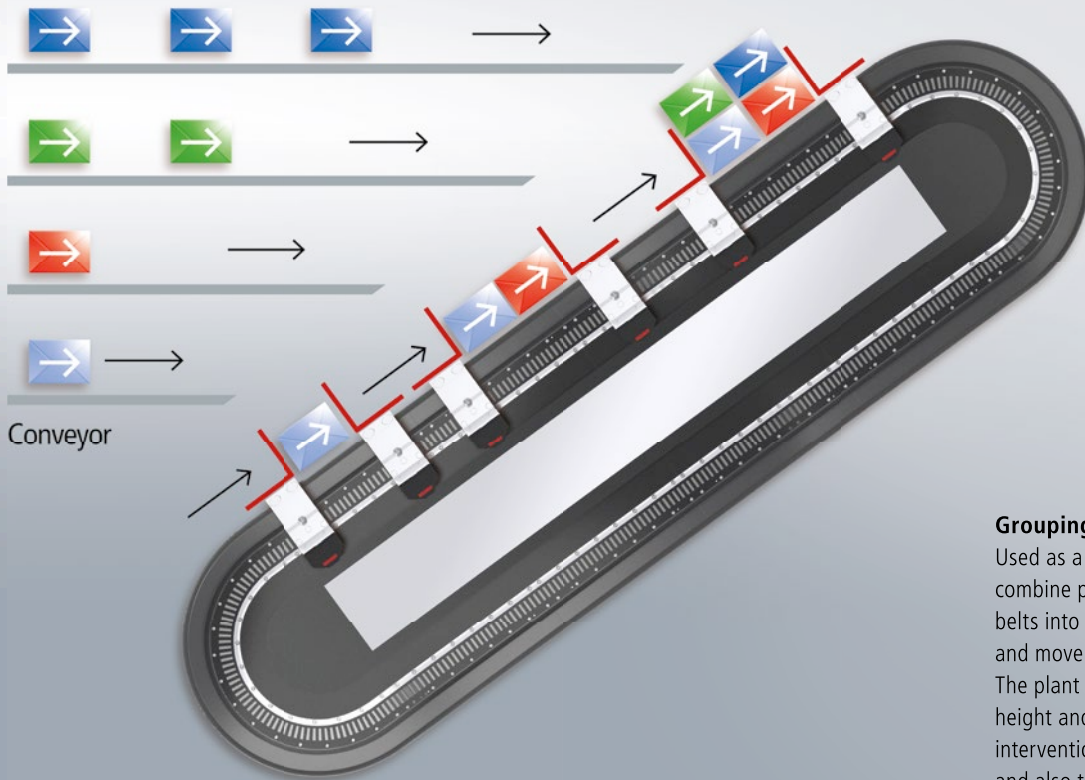

Grouping system

Used as a grouping system, the XTS can easily combine products arriving on multiple conveyor belts into predefined and easily changed groups and move them to the next station. The plant can adapt to the product width, stack height and number of stacks without any manual intervention. The distance between the movers and also the motion profile are changed by parameters in the software. This can even be done during operation without a standstill.

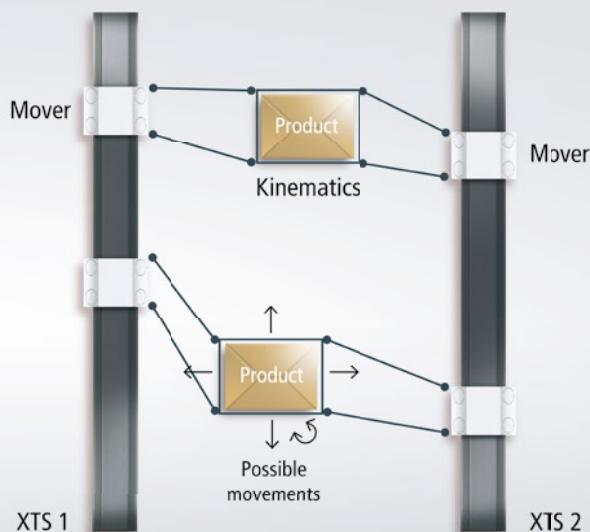

Travelling manipulator

With circulating kinematics the transported product can be influenced in X and Y directions. With two XTS systems arranged in parallel, the manipulator is synchronised to the product and shifts it on the belt at full speed. The product can even be slightly rotated by using appropriate kinematics.

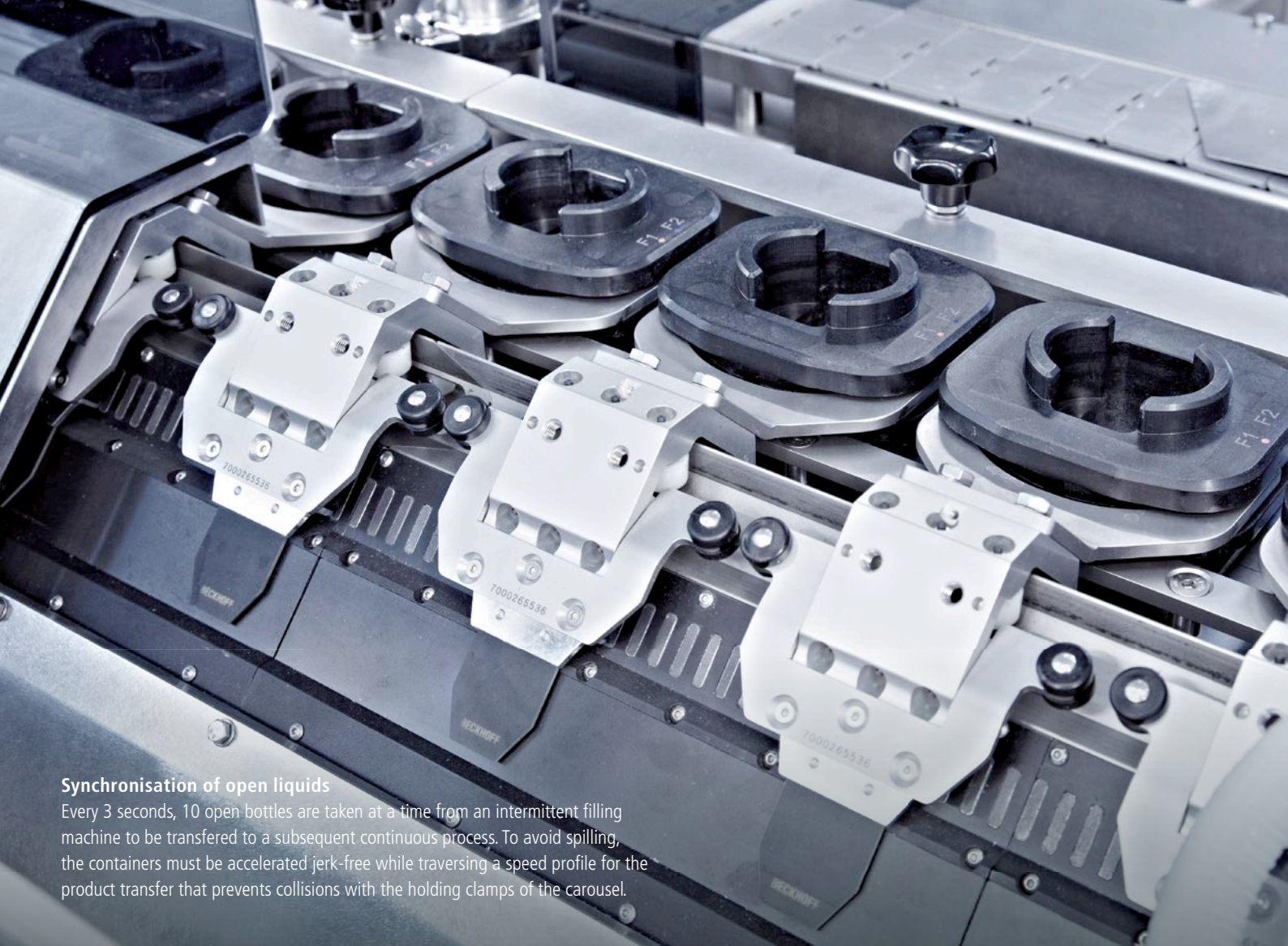

Synchronisation of open liquids

Every 3 seconds, 10 open bottles are taken at a time from an intermittent filling machine to be transferred to a subsequent continuous process. To avoid spilling, the containers must be accelerated jerk-free while traversing a speed profile for the product transfer that prevents collisions with the holding clamps of the carousel.

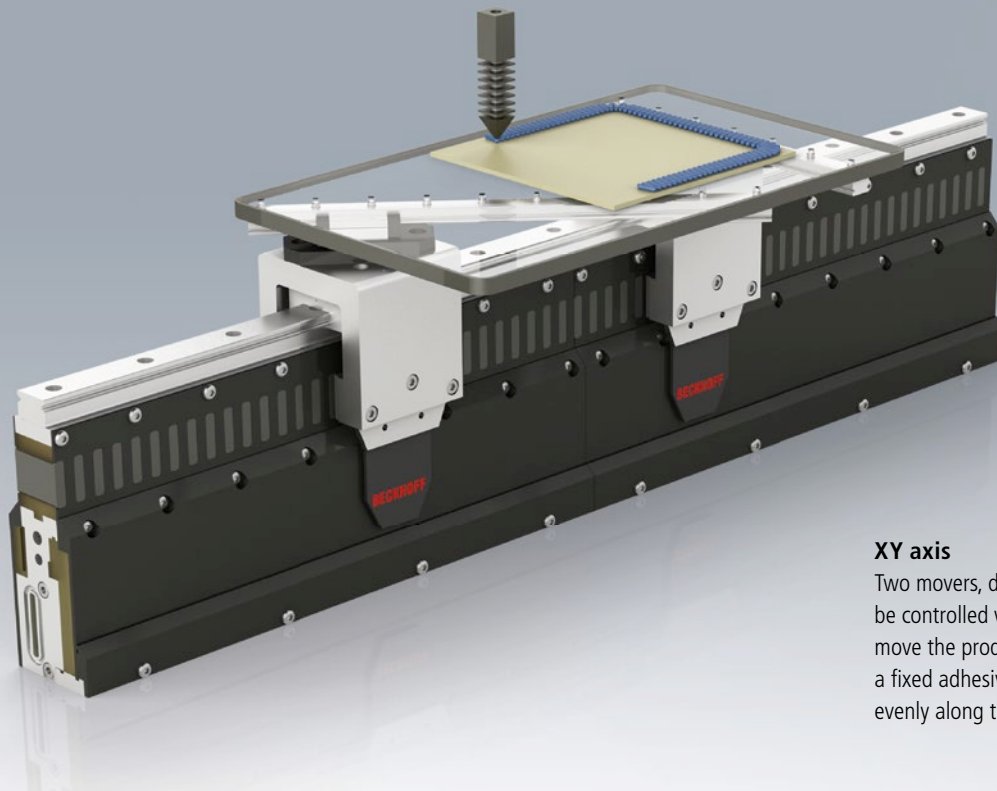

XY axis

Two movers, defined as a virtual XY axis, and can be controlled with G-code. For example, the XTS can move the product along in a targeted manner under a fixed adhesive nozzle, in order to apply adhesive evenly along the outer contour.

Technical details



| System properties | XTS |
|-------------------------------|--|
| Max. force | 100 N at standstill |
| Continuous force | 30 N (bei ~30 °C temperature increase in the motor compared to mounting frame) |
| Speed | 4 m/s @ 48 V DC supply |
| Acceleration | > 100 m/s ² (without payload) |
| Positioning accuracy | < ±0.15 mm @ 1.5 m/s |
| Absolute accuracy | < ±0.25 mm within a module |
| Repeatability | < ±10 µm (standstill) |
| Mover length | 50 mm in direction of movement |
| Mover weight | approx. 410 g (complete mover without attachments) |
| Maximum system length | >> 10 m (dependent on computing power, no system limit) |
| Operating/storage temperature | 0...+50 °C/-25...+85 °C (for further information see documentation) |
| Protection class | IP 65 |
| Approvals | CE |
| Vibration/shock resistance | conforms to EN 60068-2-6/EN 60068-2-27 |
| EMC immunity/emission | conforms to EN 61000-6-2/EN 61000-6-4 |



| Electrical data | XTS |
|-----------------------------|--|
| Supply voltage | control voltage 24 V DC, power supply 50 V DC |
| Current consumption | power supply: 16 A nominal current |
| Power consumption | motor modules: 19 W/m (communication, electronics, position determination) |
| Length per feed | max. 3 m (voltage supply, EtherCAT) |
| Power consumption per mover | approx. 12 W @ 4 m/s without payload |

► www.beckhoff.com/XTS

Motor modules

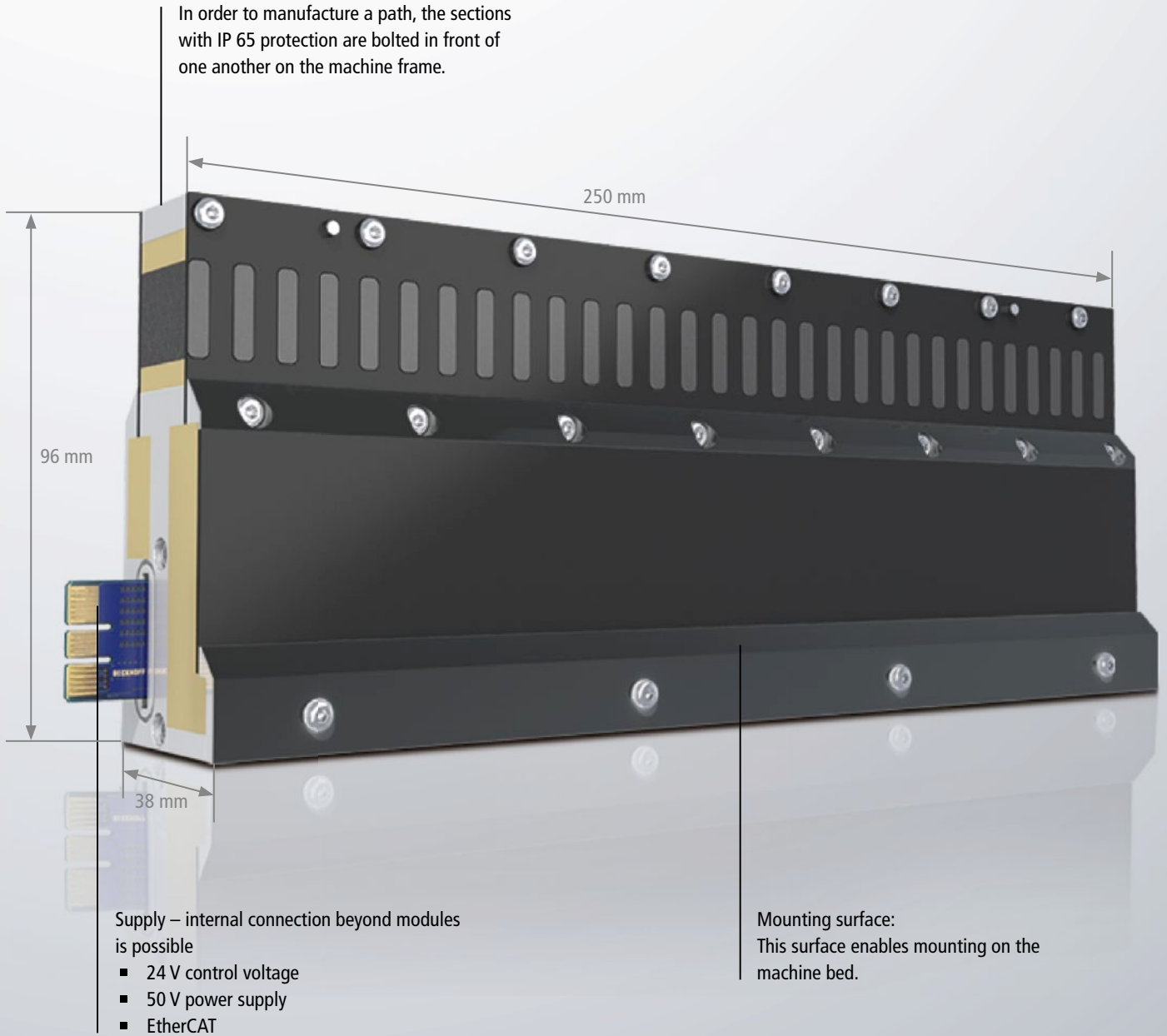

The motor module, the power electronics and the displacement measurement are built into the profile. The power electronics are optimised for the requirement and reduce assembly expenditure. There is an upper mechanical interface to the guide rail and a lower one to the support structure. Straight segments and curves can be combined arbitrarily. The geometry of the motor module without edges and openings allows easy cleaning.

Double-air-gap motor

- Double-action linear motor, hence low resulting forces on the mechanical bearing and compact design of the solution
- Displacement measurement integrated, no additional assembly, no calibration
- Tolerances are compensated automatically.
- Attractive forces neutralise each other.
- Lower force effect (wear) on the guide
- Friction losses are greatly reduced.

Output stages and coil package integrated

- No cables between coils
 - No wiring expenditure
 - Exclusion of errors
 - Minimum mounting space
 - Output stage and coil are optimally matched to each other.
- Supply voltage 50 V DC (low voltage, low safety expenditure)

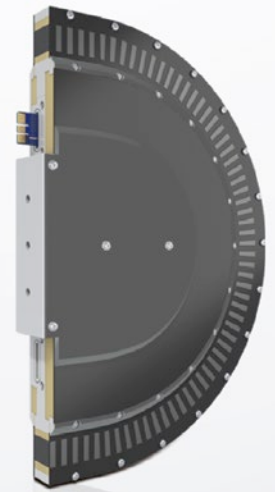

Curve motor module

| Ordering information | XTS motor modules |
|----------------------|---|
| AT2000-0250 | motor module, straight, 50 V DC/24 V DC, 250 mm x 38 mm x 96 mm (L x W x H), 2.0 kg |
| AT2001-0250 | motor module with feed, straight, 50 V DC/24 V DC, 250 mm x 38 mm x 96 mm (L x W x H), 2.2 kg |
| AT2020-0250 | motor module, 22.5° (positive curve, convex, radius constant), 50 V DC/24 V DC, 257.7 mm x 38 mm x 96 mm (L x W x H), 2.2 kg |
| AT2021-0250 | motor module with feed, 22.5° (positive curve, convex, radius constant), 50 V DC/24 V DC, 257.7 mm x 38 mm x 96 mm (L x W x H), 2.2 kg |
| AT2025-0250 | motor module, -22.5° (negative curve, concave, radius constant), 50 V DC/24 V DC, 241.9 mm x 38 mm x 96 mm (L x W x H), 2.2 kg |
| AT2026-0250 | motor module with feed, -22.5° (negative curve, concave, radius constant), 50 V DC/24 V DC, 241.9 mm x 38 mm x 96 mm (L x W x H), 2.2 kg |
| AT2040-0250 | motor module, 45° (positive curve, convex, radius constant), 50 V DC/24 V DC, 258.9 mm x 39.1 mm x 114.4 mm (L x B x H), 2.1 kg |
| AT2041-0250 | motor module with feed, 45° (positive curve, convex, radius constant), 50 V DC/24 V DC, 258.9 mm x 39.1 mm x 114.4 mm (L x B x H), 2.1 kg |
| AT2050-0500 | motor module, 180° (clothoid, radius not constant), 50 V DC/24 V DC, 307 mm x 41 mm x 195 mm (L x W x H), 4.0 kg |

Displacement measurement integrated in the motor module

- Non-contact measurement of the absolute mover position
- Positions are available immediately after switching on, no homing necessary.
- Conversion time: 20 µs (fast reaction time, good control behaviour)
- Multi-position measurement
 - The absolute positions of all movers that physically fit on a motor module are measured.
 - No position restrictions even at the module limits
- Individual mover recognition
- Repeatability 10 µm

- Independent supply of each individual coil with current is possible.
- Arbitrary number of travelling fields/movers possible
- Temperature monitoring of the output stage
- Temperature model of the coils for optimum peak load use (I²T model)
- Adaption to different mover sizes per software configuration
- Low temperature rise due to good thermal coupling to the machine bed

Guide rail

Lock for removal
of the movers

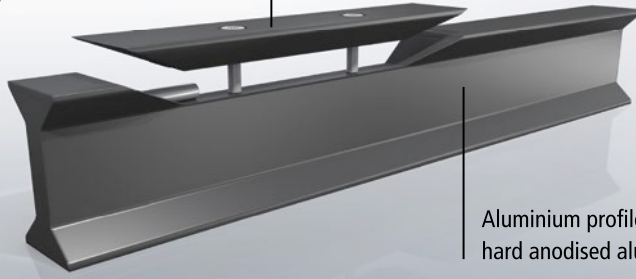

Aluminium profile rail with special
hard anodised aluminium.

The guide rail with matching movers makes the XTS system a ready-to-use solution. However, the motor modules can also be used together with the magnetic plate sets as a custom solution without the XTS guide rail.

| Technical data | AT90xx-xxxx | AT9100-xxxx | AT9000-xxxx |
|---------------------|--|--------------------|--------------|
| Design form | curve | straight with lock | straight |
| Length | – | 250-mm steps | 250-mm steps |
| Surface | hard anodised | | |
| Material | aluminium | | |
| Further information | www.beckhoff.com/AT9000 | | |

| Ordering information | XTS guide rails available to suit the motor modules |
|----------------------|---|
| AT9020-0500 | guide rail, 22.5° curve (positive curve, convex, radius constant) and 250 mm straight, suitable for 1 x AT2020-0250 and 1 x AT2000-0250 |
| AT9025-0500 | guide rail, -22.5° curve (negative curve, concave, radius constant) and 250 mm straight, suitable for 1 x AT2025-0250 and 1 x AT2000-0250 |
| AT9040-0500 | guide rail, 45° (positive curve, convex, radius constant) and 250 mm straight, suitable for 1 x AT2040-0250 and 1 x AT2000-0250 |
| AT9040-0750 | guide rail, 2 x 45° (positive curve, convex, radius constant) and 250 mm straight, suitable for 2 x AT2040-0250 and 1 x AT2000-0250 |
| AT9040-1250 | guide rail set for 180° curve, 2 parts, suitable for 4 x AT2040-0500 and 1 x AT2000-0250 |
| AT9042-2000 | guide rail set for full circle, 4 parts, suitable for 8 x AT2040-0500, with lock |
| AT9050-0500 | guide rail, 180° (clothoid), 390 mm x 22 mm x 233 mm (L x W x H), suitable for 1 x AT2050-0500 |
| AT9100-0250 | guide rail, straight, with lock, suitable for 1 x motor module AT200x-0250: 250 mm |
| AT9100-0500 | guide rail, straight, with lock, suitable for 2 x motor module AT200x-0250: 500 mm |
| AT9100-0750 | guide rail, straight, with lock, suitable for 3 x motor module AT200x-0250: 750 mm |
| AT9100-1000 | guide rail, straight, with lock, suitable for 4 x motor module AT200x-0250: 1000 mm |
| AT9100-1250 | guide rail, straight, with lock, suitable for 5 x motor module AT200x-0250: 1250 mm |
| AT9100-1500 | guide rail, straight, with lock, suitable for 6 x motor module AT200x-0250: 1500 mm |
| AT9000-xxxx | guide rails, straight, in steps of 250 mm in length, overall length up to 2.5 m, on request |
| AT9000-0250 | guide rail, straight, suitable for 1 x motor module AT200x-0250: 250 mm |
| AT9000-0500 | guide rail, straight, suitable for 2 x motor module AT200x-0250: 500 mm |
| AT9000-0750 | guide rail, straight, suitable for 3 x motor module AT200x-0250: 750 mm |
| AT9000-1000 | guide rail, straight, suitable for 4 x motor module AT200x-0250: 1000 mm |
| AT9000-1250 | guide rail, straight, suitable for 5 x motor module AT200x-0250: 1250 mm |
| AT9000-1500 | guide rail, straight, suitable for 6 x motor module AT200x-0250: 1500 mm |

► www.beckhoff.com/AT9000

Mover

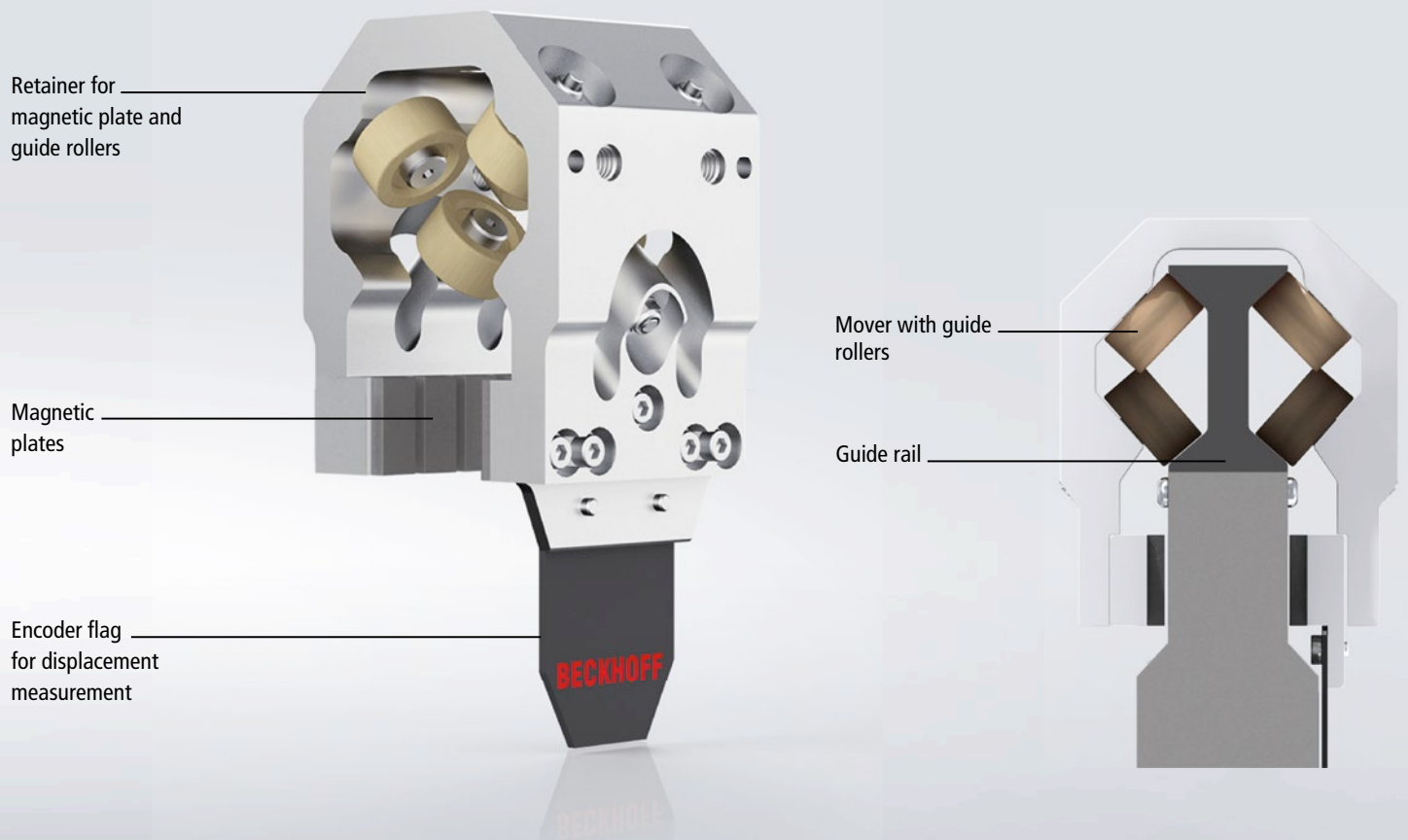

The mover is made of a light and solid aluminium alloy. Thanks to their arrangement the rollers allow backlash-free travel on the straights and in the curves. The coating of the rollers causes very little running noise and is particularly low-wear without lubrication of the guide rail. The attractive forces

of the magnetic plates are largely balanced by the opposed arrangement, so that the rollers and the rail do not have to absorb the comparatively high attractive forces of the magnets.

The centre of the encoder flag supplies a position signal to the motor module. Movers can be distinguished from each other by the encoder flags. The encoder flag is made from a sturdy, lightweight glass-fibre reinforced material

| Ordering information | XTS mover suitable for the guide rail system AT9000/AT9050 |
|----------------------|---|
| AT9011-0050-0550 | mover, 6 rollers, length 50 mm with magnetic plate set AT9001-0550, 410 g, rollers: 6 x 19 mm, plastic coated |
| AT9011-0070-0550 | mover, 6 rollers, length 70 mm with magnetic plate set AT9001-0550, 590 g, rollers: 6 x 19 mm, plastic coated |
| AT9012-0050-0550 | mover, 12 rollers, length 51 mm with magnetic plate set AT9001-0550, 450 g, rollers: 12 x 16 mm, plastic coated |

The magnetic plates can also be procured separately in order to be able to fit them to a self-developed mover. Technical boundary conditions and support on enquiry.

| Accessories | |
|-------------|---|
| AT9001-0550 | magnetic plate set, 5-pin, 50 mm, encoder flag (individually orderable, components of mover AT9011-0050-0550) |
| AT9011-1440 | encoder flag with electronic marking "Mover Standard", t = 1.4 mm, 4 absorber areas |
| AT9011-1441 | encoder flag with electronic marking "Mover 1", t = 1.4 mm, 4 absorber areas |

► www.beckhoff.com/AT9011

Software and programming

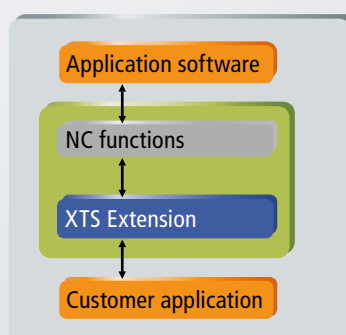
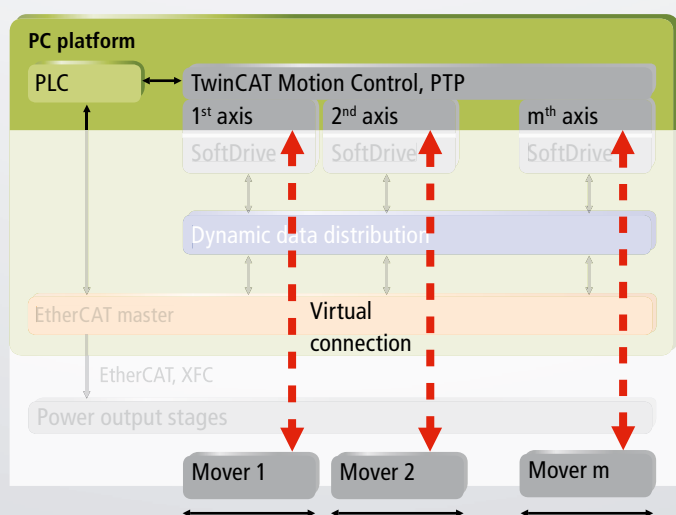
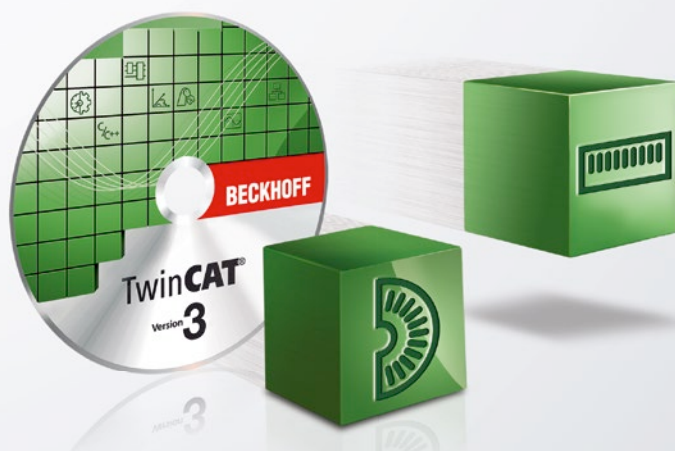

Our experienced team will support you in the production of application software.

From the point of view of application programming, a mover looks like a "normal" servo axis.

| Bestellangaben | |
|----------------|---|
| TF5000-00pp | TC3 NC PTP 10 Axes |
| TF5850-0060 | software licence, TwinCAT TC3 XTS Extension, TwinCAT 3 platform P60 (mid performance) |
| TF5850-0070 | software licence, TwinCAT TC3 XTS Extension, TwinCAT 3 platform P70 (high performance) |
| TF5850-0080 | software licence, TwinCAT TC3 XTS Extension, TwinCAT 3 platform P80 (very high performance) |

- Simple handling of the desired movements by mapping the mover as a "normal" servo axis in TwinCAT. All Motion Control functions such as flying saw, electrical gears and cam plate are usable.
- Function extensions in TwinCAT take care of typical XTS requirements: automatic accumulation, collision avoidance, jerk avoidance, centrifugal force limitation, etc.
- The integration of the XTS system into a production plant is easily possible thanks to support of numerous fieldbuses.
- Through realisation on a TwinCAT basis, the application-specific programming can be done in IEC 61131.
- All TwinCAT interfaces and functions simplify development and maintenance: remote access over Ethernet, setting of breakpoints, visualisation of arbitrary variables, etc.



Wizard: modern look, enhanced functionality

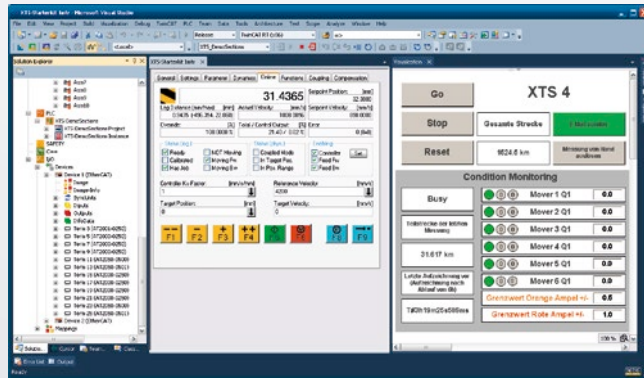

The information from the Condition Monitoring can be reduced and simplified to a "traffic light"-style status display.



The simulation provides the load for each individual coil along the path.

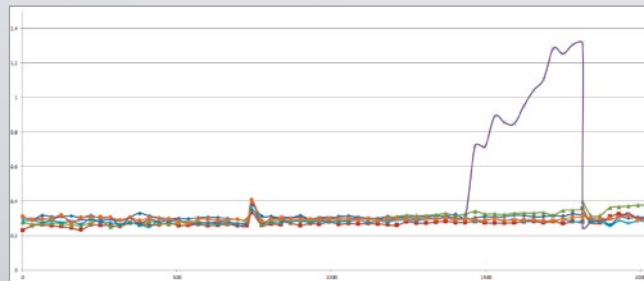

Six movers in online monitoring: the impending failure of a ball bearing shows several days in advance.

Practice-proven TwinCAT automation software controls NC axes

By means of the TC3 XTS Extension, servo algorithms are decoupled from the hardware and centrally calculated. Each output stage/coil is supplied with a current setpoint via EtherCAT.

- Each mover becomes a "servo axis".
- Synchronisation (external applications)
- Accumulation
- Drive on in accumulated groups

► www.beckhoff.com/TF5850

Starter kit

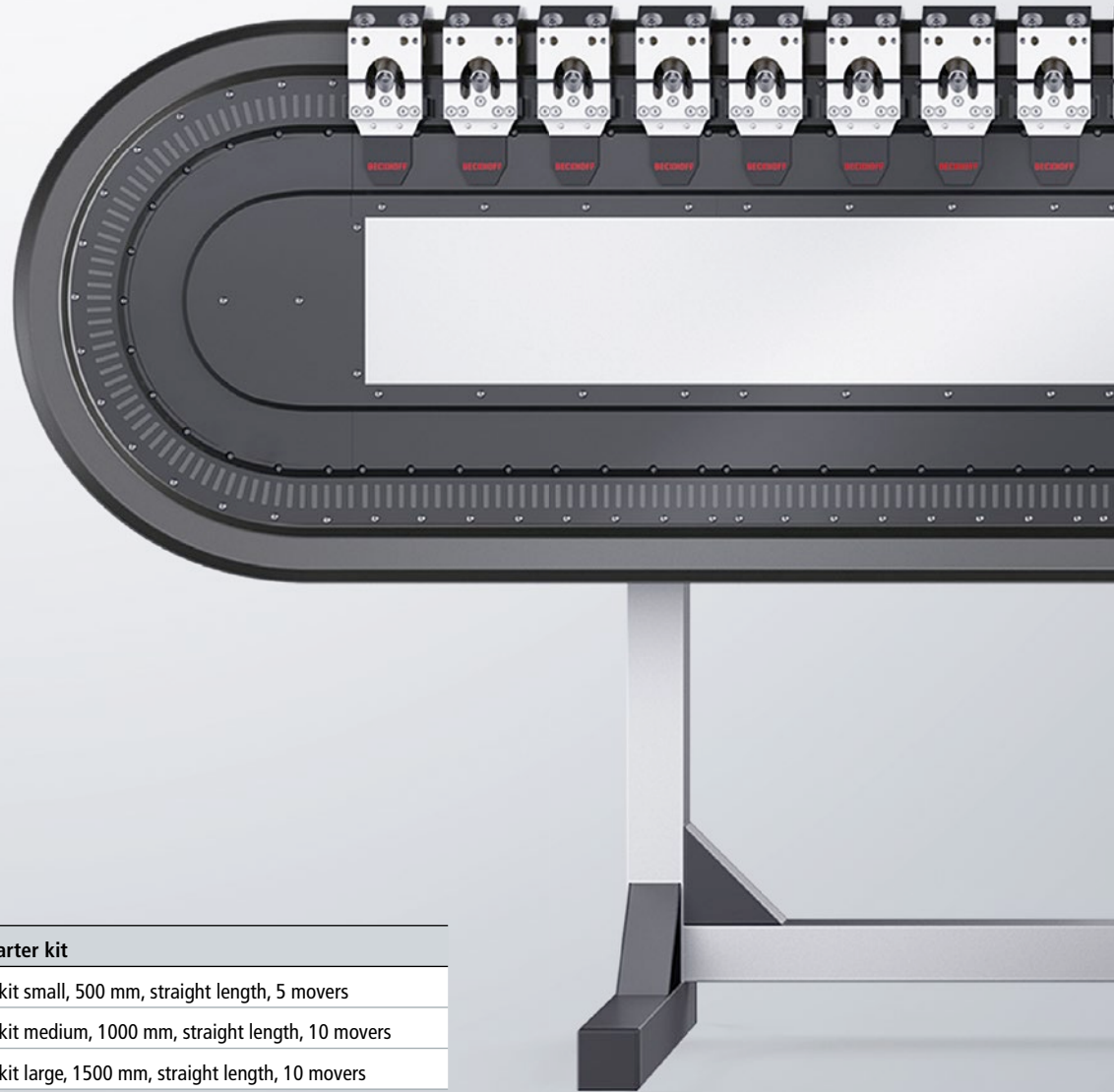

| Ordering information | XTS starter kit |
|----------------------|---|
| AT2000-0500 | starter kit small, 500 mm, straight length, 5 movers |
| AT2000-1000 | starter kit medium, 1000 mm, straight length, 10 movers |
| AT2000-1500 | starter kit large, 1500 mm, straight length, 10 movers |

The starter kit facilitates fast and effective entry to the new technology. Mechanical tests and the programming of your own motion profiles are simple to accomplish. Programming experience in IEC 61131-3 and knowledge of TwinCAT NC are required for this. The XTS starter kit contains all components required for the operation of an XTS system. The construction is fully functional and completely pre-assembled.

Basic components:

- Guide rail, assembled
- Stand and holder for all mechanical parts
- Industrial PC with all necessary interfaces and sufficient system performance
- TwinCAT NC PTP and XTS function package
- Installed in a control cabinet, fully wired, ready for operation
- Power supply units 24 V DC and 48 V DC

- 1 day instruction and programming support

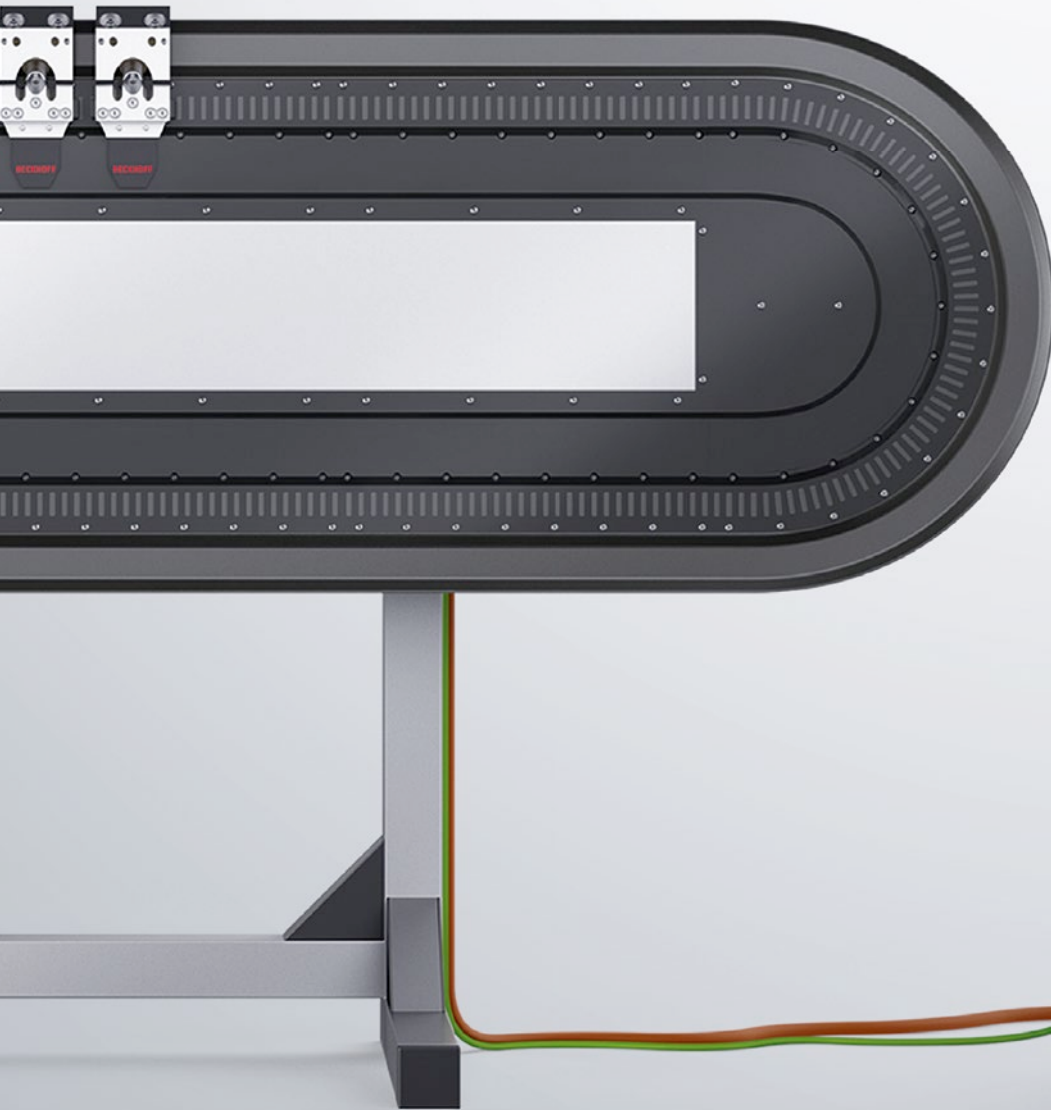

Starter kit small

- 4 x straight modules
- 2 x curve modules
- 5 x mover, with rollers, magnetic plates and encoder flag

Starter kit medium

- 8 x straight modules
- 2 x curve modules

- 10 x mover, with rollers, magnetic plates and encoder flag

Starter kit large

- 12 x straight modules
- 2 x curve modules
- 10 x mover, with rollers, magnetic plates and encoder flag

Required user skills

- Practical experience with TwinCAT
- Basic knowledge of Motion Control

www.beckhoff.com/contact

Beckhoff®, TwinCAT®, EtherCAT®, Safety over EtherCAT®, TwinSAFE®, XFC® and XTS® are registered trademarks of and licensed by Beckhoff Automation GmbH. Other designations used in this publication may be trademarks whose use by third parties for their own purposes could violate the rights of the owners.

© Beckhoff Automation GmbH & Co. KG 09/2015

The information provided in this brochure contains merely general descriptions or characteristics of performance which in case of actual application do not always apply as described or which may change as a result of further development of the products. An obligation to provide the respective characteristics shall only exist if expressly agreed in the terms of contract.